

# INSTALLATION, OPERATION & MAINTENANCE MANUAL

## Two Post Surface Mounted Lift

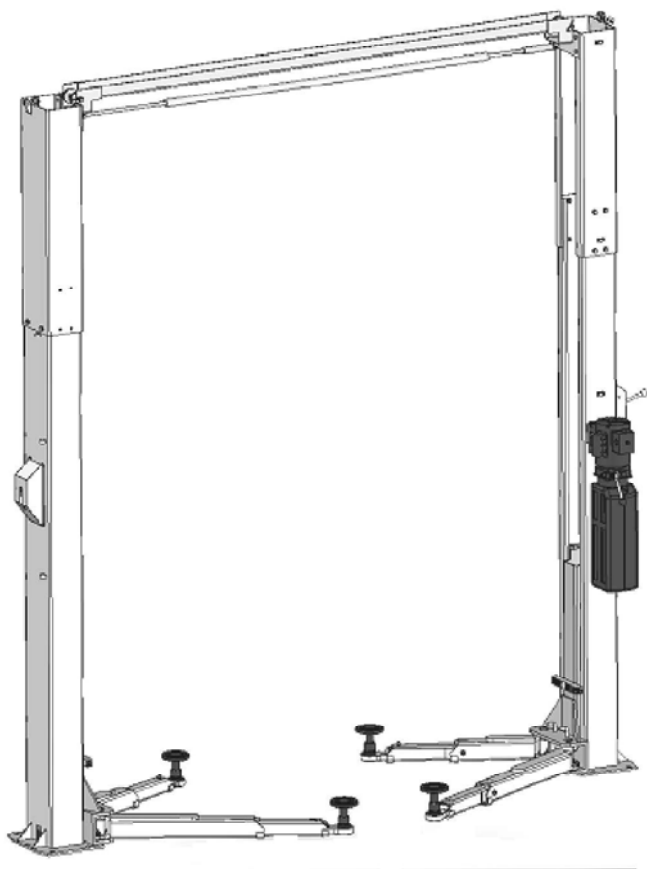

### MODEL X10

10,000 LBS. CAPACITY  
2500 LBS. PER ARM

200 Cabel Street, P.O. Box 3944 Louisville, Kentucky 40201-3944  
Email: [sales@challengerlifts.com](mailto:sales@challengerlifts.com) Web site: [www.challengerlifts.com](http://www.challengerlifts.com)

**Office 800-648-5438 / 502-625-0700 Fax 502-587-1933**

**IMPORTANT: READ THIS MANUAL COMPLETELY BEFORE  
INSTALLING or OPERATING LIFT**

GENERAL SPECIFICATIONS

See Figure 1	X10
<b>A</b> Rise Height (Screw Pads Highest Position)	79 1/8" (2010mm)
<b>B</b> Overall Height	151 1/2" (3848mm)
<b>C</b> Overall Width	131 1/2" (3340mm)
<b>D</b> Drive-Thru Clearance	98" (2489mm)
<b>E</b> Floor to Overhead Switch	144" (3658mm)
<b>F</b> Short Arm Reach	21 3/4"-40" (552mm-1016mm)
<b>G</b> Long Arm Reach	35 7/8"-55 3/8" (911mm-1407mm)
<b>H</b> Screw Pad Height	4 3/4"-8 1/2" (121mm-216mm)
<b>K</b> Inside of Columns	109 7/8" (2791mm)
Lifting Capacity *	10,000 lbs. (4536 kg)
Ceiling Height Required	152 1/2" (3874mm)
Motor	2HP, Single Phase, 60Hz
Voltage	208-230
Speed of Rise **	52 seconds
Max Load Per Arm	2500 lbs (1134 kg)

\* Lift capacity ratings are based on loads equally distributed on all four arms.

\*\* Lifting and lowering speeds may vary depending on the weight of the vehicle.

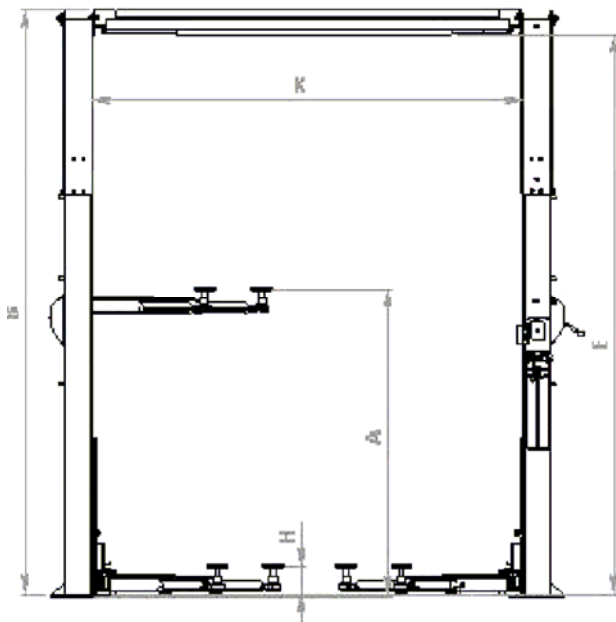

Fig 1a - General Specifications

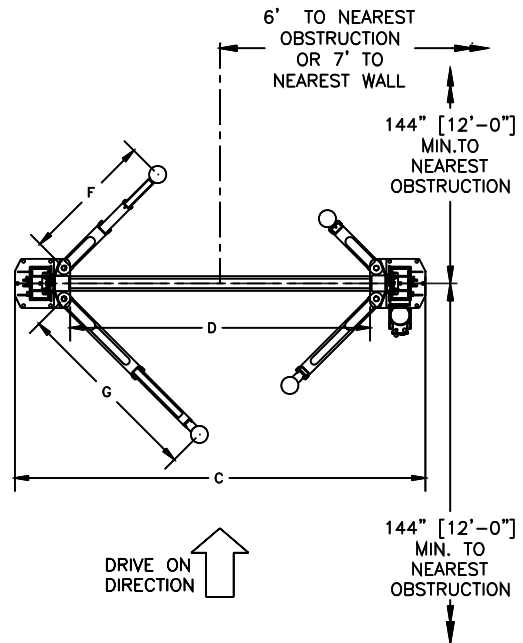

Fig1b - Service Bay Layout

## VERTICAL CLEARANCE

Check the height of the area where the lift is to be installed. Clearance should be calculated based on the full raised height of the lift.



**Failure by purchaser to provide adequate clearance could result in unsatisfactory lift performance, property damage, or personal injury.**

## FLOORING

Be certain you have the proper concrete floor to properly handle the loaded lift. Floor should be in generally good condition with no large cracks, spalling or deterioration.

**Minimum requirements for concrete are 4 inches minimum depth, with steel reinforcement, 3500 psi, cured for 28 days per local commercial practice.** Floor should be level within 3/8 inch over the installation area. No anchors should be installed within 8 inches of any crack, edge, or expansion joint. If these conditions cannot be met, a pad may be poured to accommodate the lift.

Check with local building inspectors and/or permits office for any special instructions or approvals required for your installation.



**Failure by purchaser to provide the recommended mounting surface could result in unsatisfactory lift performance, property damage, or personal injury.**

## ELECTRICAL REQUIREMENTS

**For lift installation and operation for single phase units, it is necessary to have a dedicated circuit with a double pole 25 amp circuit breaker or time delay fuse.**

## SAFETY NOTICES AND DECALS

For your safety, and the safety of others, read and understand all of the safety notices and decals included here.

**READ ENTIRE MANUAL BEFORE ASSEMBLING, INSTALLING, OPERATING, OR SERVICING THIS EQUIPMENT.  
PROPER MAINTENANCE AND INSPECTION IS NECESSARY FOR SAFE OPERATION.  
DO NOT OPERATE A DAMAGED LIFT.**

Safety decals similar to those shown here are found on a properly installed lift. Be sure that all safety decals have been correctly installed on the Power Unit reservoir. Verify that all authorized operators know the location of these decals and fully understand their meaning. Replace worn, faded, or damaged decals promptly.



**Do not attempt to raise a vehicle on the lift until the lift has been correctly installed and adjusted as described in this manual.**

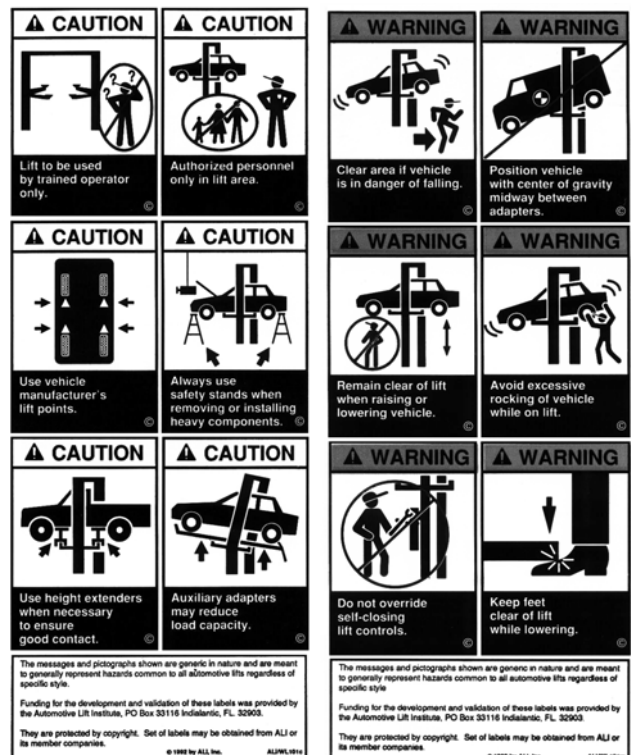

## RECEIVING

The shipment should be thoroughly inspected as soon as it is received. The signed bill of lading is acknowledgement by the carrier of receipt in good condition of shipment covered by our invoice.

If any of the goods called for on this bill of lading are shorted or damaged, do not accept them until the carrier makes a notation on the freight bill of the shorted or damaged goods. Do this for your own protection.

NOTIFY **Challenger Lifts** AT ONCE if any hidden loss or damage is discovered after receipt.

IT IS DIFFICULT TO COLLECT FOR LOSS OR DAMAGE AFTER YOU HAVE GIVEN THE CARRIER A CLEAR RECEIPT.

File your claim with **Challenger Lifts** promptly. Support your claim with copies of the bill of lading, freight bill, and photographs, if available.

## Component Packing List

PART #	QTY/ LIFT	DESCRIPTION
X10-004	1	Power Column Ass'y
X10-005	1	Idler Column Ass'y
X10-006	1	Overhead Ass'y
X10-001	1	Hardware Box
X10-007	1	Power Column Extension
X10-008	1	Idler Column Extension
X10-009	2	Rear Arm Ass'y
X10-010	2	Front Arm Ass'y
X10-011	2	Synchronizer Cable Ass'y
X10-012	1	Hydraulic Hose Pack
X10-013	1	Power Lock Cover
X10-014	1	Idler Lock Cover

## INSTALLATION

IMPORTANT: Always wear safety glasses while installing lift.

### TOOLS (MINIMUM REQUIRED)

- Tape measure, 16ft
- Chalk line
- 4ft level
- 10" adjustable wrench
- Metric open end wrenches 10mm, 13mm, 14mm, 15mm, 17mm, 18mm, 19mm and 24mm
- Metric Allen Wrenches 4mm, 5mm, 6mm, and 8mm.
- Needle Nose pliers
- Snap Ring pliers
- Hammer drill with 3/4" diameter carbide tipped bits
- 2lb hammer
- Torque wrench: 150 foot pounds minimum with 1 1/8" socket
- 12 ft. Step ladder
- Anti-Seize lubricant (for arm pins)

### LAYOUT

- Layout the service bay according to the architect's plans or owners instructions (**see Fig 1b**). **Failure to install in this orientation can result in personal and property damage.** Be certain that the proper conditions exist, see page 3.
- Assemble column extension to column using M12 x 30 Hex bolts. Repeat for opposite column and extension.
- Using the Overall Width (C) Dimension from **Fig 1b**, chalk two parallel lines on the floor within 1/8" tolerance. Erect both column assemblies. Align the base plate edges to the chalk lines.

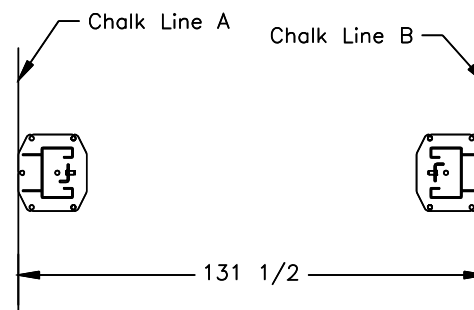

### ANCHORING

- The anchor bolts must be installed at least 8" from any crack, edge, or expansion joint.
- Use a concrete hammer drill with a 3/4 inch carbide bit. Tip diameter should conform to ANSI Standard B94.12-1977 (.775 to .787). Do not use excessively worn bits or bits which have been incorrectly sharpened. A

core bit may be necessary if an obstruction is encountered. **Never substitute with shorter anchor.**

- 6) Recheck "Inside of Columns" dimension, **Fig 1**. Drill the anchor holes using the base plate as a template. Drill through the floor if possible or to a depth of 5 inches minimum.
- 7) Vacuum dust from the hole for proper holding power.
- 8) Shim both columns to plumb using the shims provided as shown in **Fig 2**. **DO NOT** shim more than 1/2" at any given point. Use a level no less than 24" in length to plumb columns.
- 9) Assemble washer and nut to anchor with nut just below impact section of bolt. Drive anchor into hole until nut and washer contact base.

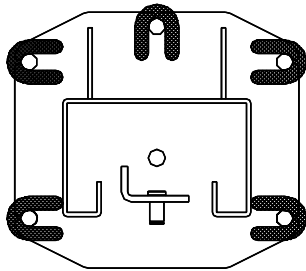

**Fig 2 – Column Shimming**

- 10) Tighten power column anchors and recheck column for plumb. Re-shim if necessary. Torque to 150 foot-pounds to set anchors.

#### OVERHEAD

- 11) Raise and install Overhead Assembly using M12 x 30 Hex Bolts.
- 12) Install Overhead Limit Switch under the Overhead Assembly on the Power Side. Route cable around outside of column as shown in **Fig. 5**.
- 13) Check idler column shimming. Use additional shims (**see Fig. 2**) to remove any gaps that may have been created while installing overhead beam. Tighten anchor bolts and re-check column for plumb. Torque to 150 foot-pounds.

#### SYNCHRONIZER CABLES

- 14) Manually raise each carriage into the second lock position.
- 15) Attach one end of synchronizing cable to carriage. See **Fig 3** for proper attachment.
- 16) Route cable up and over sheave in overhead. Follow across to other sheave on opposite column. Route down through opposite carriage to sheave in bottom of column. Route under sheave and up to cable attachment. Use **Fig 7** for proper attachment.

- 17) Repeat for opposite side.

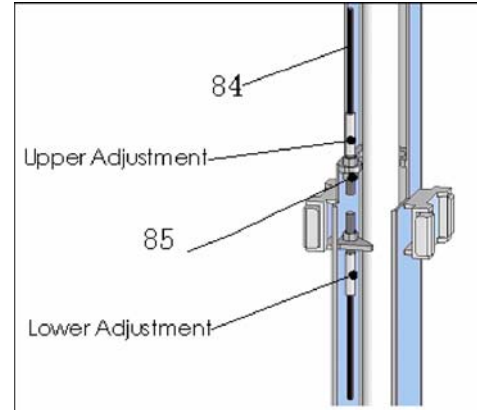

**Fig 3 – Synchronizing Cables**

#### POWER UNIT & HYDRAULIC LINES

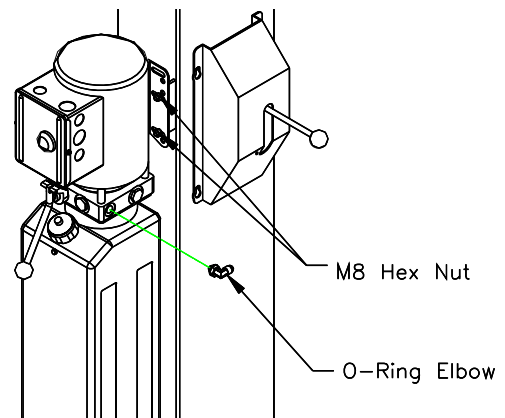

**Fig 4 – Power Unit Mounting**

- 18) Mount Power Unit to power column as shown in **Fig 4**. The mounting hardware, (4) M8 hex nuts, are pre-installed on power unit mounting bracket.
- 19) Attach Hydraulic elbow fitting threading the O-Ring end into the power unit.
- 20) **IMPORTANT – To insure proper hose fitting seal without damage to the fitting follow this procedure for each hose connection:** Screw flared fitting on finger tight. Rotate flared fitting 1 1/2 flats or 90 degrees. Back the flared fitting off one full turn and repeat.
- 21) Thread power unit hose (short) to elbow in power on power unit.
- 22) Route Idler Column Hose (long) beginning at the elbow fitting at the base of the idler column up the backside of the column through the three capture rings. Continue across the overhead and down the backside of the power column. Each column extension is equipped with a bushed chase at the top. **See Fig 5.**

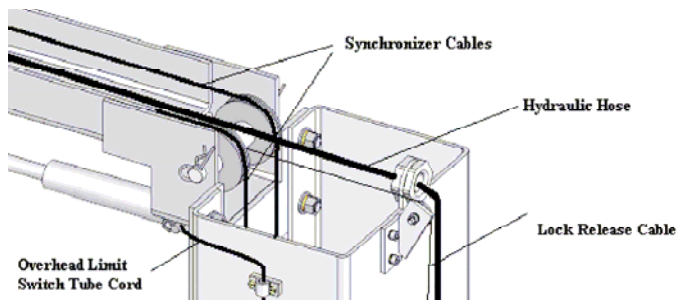
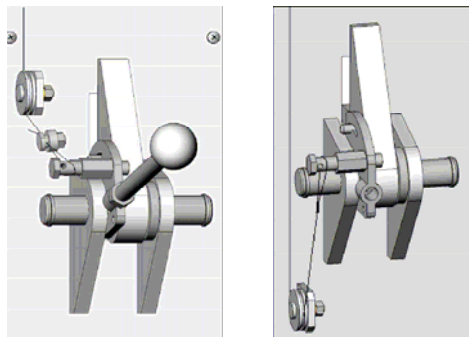

**Fig 5 – Hose Routing**

- 23) Route the remaining Power column hose beginning at the elbow fitting at the base up the backside of the column. Join the three hoses with the supplied union tee.
- 24) **BE CERTAIN ALL FITTINGS AND CONNECTIONS ARE TIGHT. IT IS THE INSTALLERS RESPONSIBILITY TO INSURE SYSTEM IS LEAK-FREE.** Fill the Power Unit with three gallons of clean 10wt anti-foam anti-rust hydraulic oil or Dexron III ATF. **DO NOT USE OILS WITH DETERGENTS.**

**LOCK RELEASE**

- 25) Install Lock Release Stud and Knob to the Powre Column Lock using one M10 Nut.
- 26) Attach Mechanical Lock Release Cable Assembly to each lock pawl. **See Fig 6.**



**Power Side**

**Idler Side**

**Fig 6 – Lock Assembly**

**THE LOCK RELEASE CABLE ADJUSTMENT IS NOT COMPLETE UNTIL THE LIFT HAS BEEN LOWERED AND “FINAL ADJUSTMENTS” HAVE BEEN MADE.**

**ARM INSTALLATION**

- 27) Lubricate the arm pin or carriage arm pin hole with “anti-seize” and install the arms. Insure that the arm restraint gears engage and disengage properly. Arm restraints should disengage when lift is fully lowered.

**ELECTRICAL**

- 28) Refer to **Fig 7 Wiring Diagram** for all steps under this heading.

**Single Phase**

- 29) Connect the Overhead Limit Switch Cord to Power Unit as shown.
- 30) Connect Power Unit to suitable electrical source as shown.

**Three Phase**

- 31) Power unit is factory wired for 240 volt. Refer to wiring diagram or motor plate for optional voltages.
- 32) Connect Contactor Enclosure to column. Mounting hardware should be centered on the column side to side to avoid the path of the slide blocks.
- 33) Connect Overhead Limit Switch Cord to Contactor as shown.
- 34) Connect Contactor to Power unit as shown. Connect Contactor to suitable electrical source as shown.

**IMPORTANT:** AFTER WIRING HAS BEEN COMPLETED, TEST OPERATION OF POWER UNIT & OVERHEAD LIMIT SWITCH. WHILE RAISING LIFT, OPERATE OVERHEAD SHUTOFF BAR. POWER UNIT MOTOR SHOULD STOP WHEN SHUTOFF BAR IS RAISED.

**FINAL ADJUSTMENTS**

**HYDRAULICS**

- 35) Lower the lift to the floor and raise the lift approximately one foot.
- 36) Start with Idler side first. Slowly and carefully loosen the bleed plug on top side of the cylinder just enough to allow the entrapped air to escape. Repeat for power side.
- 37) Raise lift 6 inches. Repeat step 32 until no air comes out of cylinder.
- 38) Pressure test hydraulic system. Energize power unit, raise lift to full rise and continue to run motor for additional 10 seconds. (NOTE: pressure relief will make a high pitch squeal sound for these 10 seconds.) Check hydraulic system for leaks.
- 39) Energize power unit again for 10 seconds. With a clean rag, wipe down both cylinder rods. (The cylinders are shipped with a small amount of clear anti-corosive lubricant that will be forced out through the wiper when the lift reaches full rise.) **If lubricant is not wiped clean from the cylinder rod, the cylinder will appear to be leaking.**

# Wiring Diagram

**\* After wiring has been completed, test operation of Power Unit & Overhead Limit Switch. While raising lift, operate Overhead Shutoff Bar. Power Unit Motor should stop when Shutoff Bar is raised.**

EACH LIFT SHOULD HAVE A DEDICATED CIRCUIT WITH A DOUBLE POLE (THREE POLE FOR 440-480V) BREAKER OR TIME DELAY FUSE SIZED ACCORDING TO THE FOLLOWING CHART

	1Ø 208-240V	3Ø 208V	3Ø 220-240V	3Ø 440-480V
2Hp	25amp	15amp	15amp	5amp

**\* WIRING MUST COMPLY WITH NEC AND ALL LOCAL ELECTRICAL CODES \***

## FOR SINGLE PHASE

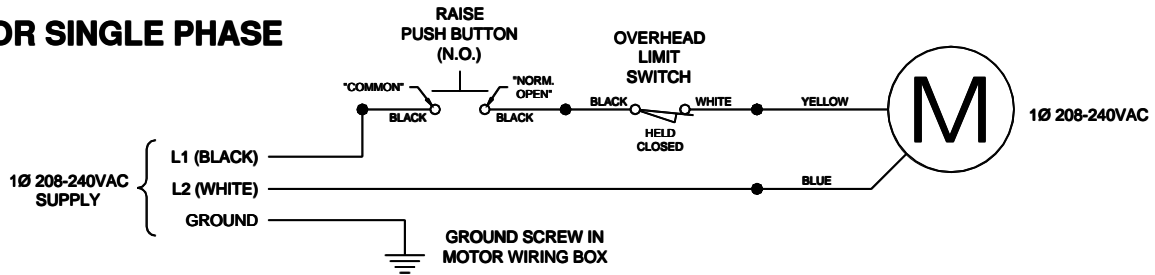

## FOR THREE PHASE

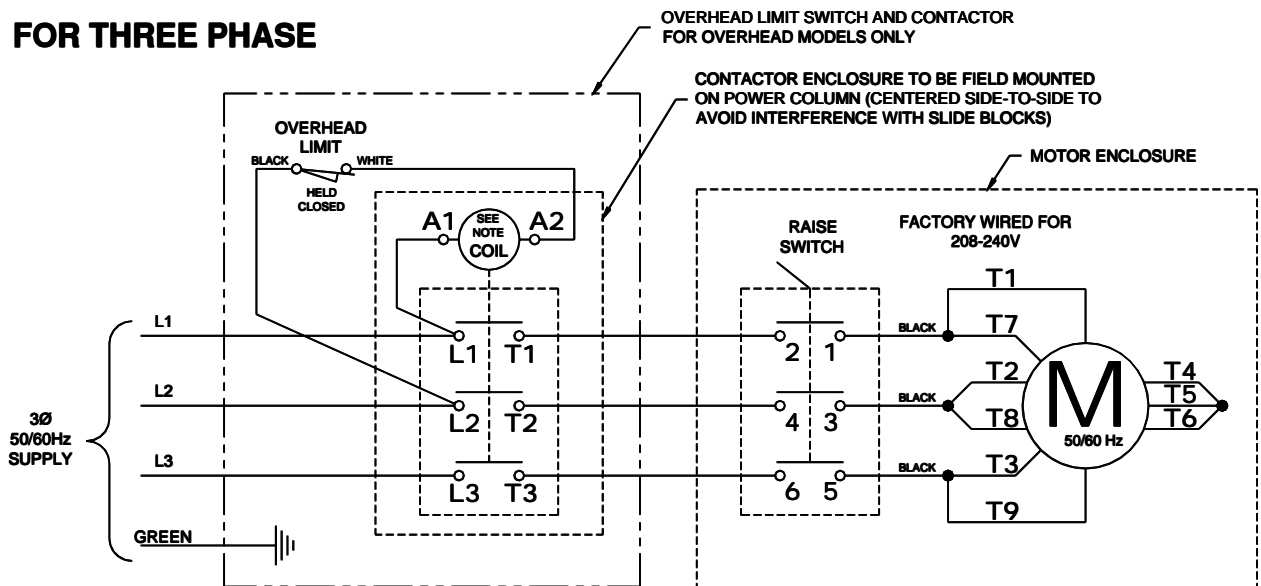

### NOTES:

- 1) MOTOR IS FACTORY WIRED FOR 208V OR 220-240V SUPPLY
- 2) MOTOR CONNECTIONS MUST BE RECONFIGURED PER THIS DIAGRAM FOR 440-480V SUPPLY
- 3) CONTACTOR COIL RATING MUST MATCH SUPPLY VOLTAGE (208V, 220-240V, OR 440-480V)
- 4) CONTACTOR MUST BE FIELD MOUNTED ON POWER COLUMN (CENTERED SIDE-TO-SIDE TO AVOID INTERFERENCE WITH SLIDE BLOCKS)
- 5) MOTOR ROTATION IS COUNTER CLOCKWISE FROM TOP OF MOTOR

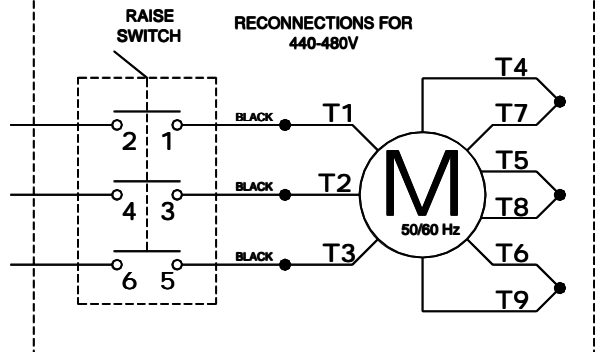

Fig 7 – Electrical Wiring Diagram

## FINAL ADJUSTMENTS (CONTINUED)

### SYNCHRONIZING CABLES

- 40) Raise lift and insure carriages lower into same lock position.
- 41) Adjust synchronizing cables so the tension is equal in both cables and carriages are firmly sitting on locks.
- 42) Cycle lift to insure that latches operate simultaneously.

### LOCK RELEASE CABLE

- 43) Raise lift to a lock position but don't set into the lock. Pull and release Power Column lock release handle while watching Idler Column lock. Adjust Cable tension by removing slack and retightening cable clamp at the power side. **IMPORTANT: IF IDLER SIDE LOCK PAWL DOES NOT FULLY DISENGAGE, DAMAGE MAY RESULT TO IDLER SIDE CARRIAGE AND OR CABLE SYNCHRONIZING SYSTEM.**
- 44) Tighten and trim wire ties.
- 45) Remove lock release knob and install both covers. Replace lock release knob.

### OWNER/OPERATOR CHECKLIST

- 46) Demonstrate the operation of the lift to the owner/operator and review correct and safe lifting procedures using the Lifting It Right booklet as a guide.
- 47) Complete the Installation Checklist/Warranty Validation questionnaire with the owner. Review the terms of the warranty registration card, and return the card and a copy of the questionnaires to:

*Challenger Lifts, Inc.*  
200 Cabel Street  
Louisville, KY. 40206

## OPERATION PROCEDURE

### SAFETY NOTICES AND DECALS

**This product is furnished with graphic safety warning labels, which are reproduced on page 3 of these instructions. Do not remove or deface these warning labels, or allow them to be removed or defaced. For your safety, and the safety of others, read and understand all of the safety notices and decals included.**

### OWNER/EMPLOYER RESPONSIBILITIES

This lift has been designed and constructed according to ANSI/ALI ALCTV-1998 standard. The standard applies to lift manufactures, as well as to owners and employers. The owner/employer's responsibilities as prescribed by ANSI/ALI ALOIM-2000, are summarized below. For exact wording refer to the actual standard provided with this manual in the literature pack.

**The Owner/Employer shall** insure that lift operators are qualified and that they are trained in the safe use and operation of the lift using the manufacturer's operating instructions; ALI/SM 93 -1, ALI Lifting it Right safety manual; ALI/ST-90 ALI Safety Tips card; ANSI/ALI ALOIM-2000, American National Standard for Automotive Lifts-Safety Requirements for Operation, Inspection and Maintenance; ALI/WL Series, ALI Uniform Warning Label Decals/Placards; and in case of frame engaging lifts, ALI/LP-GUIDE, Vehicle Lifting Points/Quick Reference Guide for Frame Engaging Lifts.

**The Owner/Employer shall** establish procedures to periodically inspect the lift in accordance with the lift manufacturer's instructions or ANSI/ALI ALOIM-2000, American National Standard for Automotive Lifts-Safety Requirements for Operation, Inspection and Maintenance; and the employer shall insure that the lift inspectors are qualified and that they are adequately trained in the inspection of the lift.

**The Owner/Employer shall** establish procedures to periodically maintain the lift in accordance with the lift manufacturer's instructions or ANSI/ALIOIM-2000, American National Standard for Automotive Lifts-Safety Requirements for Operation, Inspection and Maintenance; and the employer shall insure that the lift maintenance personnel are qualified and that they are adequately trained in the maintenance of the lift.

**The Owner/Employer shall** maintain the periodic inspection and maintenance records recommended by the manufacturer or ANSI/ALI ALOIM-2000, American National Standard for Automotive Lifts-Safety Requirements for Operation, Inspection and Maintenance.

**The Owner/Employer shall** display the lift manufacturer's operating instructions; ALI/SM 93 -1, ALI Lifting it Right safety manual; ALI/ST-90 ALI Safety Tips card; ANSI/ALI ALOIM-2000, American National Standard for Automotive Lifts-Safety Requirements for Operation, Inspection and Maintenance; and in the case of frame engaging lift, ALI/LP-GUIDE, Vehicle Lifting Points/Quick Reference Guide for Frame Engaging Lifts; in a conspicuous location in the lift area convenient to the operator.



#### LIFTING A VEHICLE

- 1) Insure that the lifting arms are parked, out to full drive thru position.
- 2) Position the vehicle in the service bay so that the vehicle's center of gravity is on a line between the two columns, and so the vehicle is centered between the two columns.

**DO NOT EXCEED 2500 POUNDS PER ARM.**

**DO NOT ATTEMPT TO LIFT THE VEHICLE WITH ONLY TWO ARMS, AS THIS WILL VOID THE WARRANTY**

**INSURE THAT THE HIGHEST POINT ON THE VEHICLE WILL CONTACT THE OVERHEAD LIMIT SWITCH BAR.**

**DO NOT PLACE THE VEHICLE IN THE SERVICE BAY BACKWARDS.**

**REFER TO THE VEHICLE MANUFACTURERS SERVICE MANUAL, TECHNICAL BULLETINS, "VEHICLE LIFTING POINTS GUIDE" (ALI/LP-GUIDE) OR OTHER PUBLICATIONS TO LOCATE THE RECOMMENDED LIFTING POINTS.**

- 3) Position the arms and adapters so all four pads contact the vehicle simultaneously.

**The vehicle should remain level during lifting.**

- 4) Raise the lift until all four wheels are off the ground. Test the stability of the vehicle by attempting to rock the vehicle. Check adapters for secure contact with vehicle lift points. If the vehicle seems unstable, lower the lift and readjust the arms. If the vehicle is stable, raise the vehicle to a height a few inches above the desired working height.
- 5) Lower the vehicle until the safety latches on both columns engage. The vehicle should remain level when both latches are engaged. If one side engages and the other continues to descend, stop lowering the vehicle, raise it several inches, and try again to engage both latches.

**Always lower lift into locks before entering the area beneath the vehicle.**

**Always use safety stands when removing or installing heavy components.**

#### LOWERING A VEHICLE

- 1) Insure that the area under the vehicle is clear of personnel and tools.
- 2) Raise the vehicle until both latches are free.
- 3) Disengage the latches by pulling down and holding the lock release lever.
- 4) Lower the vehicle by depressing the lowering valve handle.
- 5) Continue to lower the vehicle until the carriages stop against the base plate. Retract the extension arms, and park them.

#### MAINTENANCE

To avoid personal injury, permit only qualified personnel to perform maintenance on this equipment.

The following maintenance points are suggested as the basis of a preventive maintenance program. The actual maintenance program should be tailored to the installation. See ANSI/ALI ALOIM booklet for periodic inspection checklist and maintenance log sheet.

- If lift stops short of full rise or chatters, check fluid level and bleed both cylinders per Installation Instructions.
- Replace all Safety, Warning or Caution Labels if missing or damaged (**See Installation instructions page 3.**)

#### Daily

- Keep lift components clean.
- Check for loose or broken parts.
- Check hydraulic system for fluid leaks.
- Check adapters for damage or excessive wear. Replace as required with genuine Challenger Lifts parts.
- Check lock release activation. When properly adjusted, the idler column lock should rest firmly against the back of the column when engaged and pull clear of the column back when disengaged.

#### Weekly

- Check synchronizer cables and sheaves for wear. Replace as required with genuine Challenger Lifts parts.
- Check lock release cable adjustment per Installation Instructions step 39.

**IMPORTANT: IF IDLER SIDE LOCK PAWL DOES NOT FULLY DISENGAGE, DAMAGE MAY RESULT TO IDLER SIDE CARRIAGE AND OR CABLE SYNCHRONIZING SYSTEM.**

- Check synchronizer cable tension per Installation Instructions. Adjust if necessary.

#### Monthly

- Torque concrete anchor bolts to 80 ft-lbs.
- Check overhead shutoff switch. While raising lift, operate overhead shutoff bar. Power Unit motor should stop when bar is raised.
- Lubricate carriage slide tracks with heavy viscous grease. (Grease all (4) corners of both columns.)

**If any problems are encountered, contact your local service representative.**

Model X10  
Installation, Operation and Maintenance

### Parts Breakdown

Item #	Part #	Qty.	Description	Item #	Part #	Qty.	Description
1	X10-015	1	Power Column Weld	44	X10-055	4	Washer
	X10-016	1	Idler Column Weld	45	X10-056	4	Spacer Sleeve
2	X10-007	1	Power Extension Weld	46	X10-057	6	Synch. Sheave
	X10-008	1	Idler Extension Weld	47	X10-058	2	Axle
3	X10-013	1	Power Lock Cover	48	X10-059	2	Middle Spacer Sleeve
	X10-014	1	Idler Lock Cover	49	X10-060	2	Bolt M8 x 25
4	X10-065	8	Screw M5 x10	50	36027	1	Limit Switch
5	X10-017	1	Lock Release Knob	51	X10-061	1	Shutoff Bar Cushion
6	X10-018	1	Lock Release Stud	52	X10-062	1	Shutoff Bar
7	X10-019	1	Nut M10	53	X10-063	1	Bolt M8
8	X10-020	4	"C" Ring 20	54	X10-064	1R/1L	Pulley Bracket
9	X10-021	2	Lock Release Wire Pin	55A	B1104	4	Rubber Pad
10	X10-022	2	Lock Release Spring 1	56A	X10-066	4	Screw Pad
11	X10-023	2	Lock Release Spring 2	57	X10-067	4	Snap Ring 30mm
12	X10-024	2	Lock Release Shaft	58	X10-068	8	Snap Ring 45mm
13	X10-025	2	Lock Release Cam	59	X10-069	4	Threaded Insert
14	X10-026	2	Bolt M6	60	X10-070	4	Sleeve
15	X10-027	2	Spring Pin 6 x 35	61	X10-071	2	Rear Male Arm
16	X10-028	2	Lock Pawl	62	X10-072	2	Rear Female Arm
17	X10-029	2	Washer	63	X10-073	6	Washer 10mm
18	X10-030	4	Pulley Axle	64	X10-074	18	Spring Washer 10mm
19	X10-031	4	Pulley	65	X10-075	6	Screw M10
20	X10-032	8	Washer 6mm	66	X10-076	4	Arm Pin
21	X10-033	8	Spring Washer 6mm	67	X10-077	12	Screw M10 x 25
22	X10-034	9	Nut M6	68	X10-078	4	Inner Gear
23	X10-035	1	Bolt (Cable Clamp)	69	X10-079	4	Arm Restraint Pin
24	X10-036	1	Sleeve	70	X10-080	4	Spring Pin 4 x 24
25	X10-037	28	Bolt M12 x 30	71	X10-081	4	Spring Pin 4 x 30
26	X10-038	28	Washer 12mm	72	X10-082	4	Arm Restraint Spring
27	X10-039	28	Spring Washer 12mm	73	X10-083	4	Outer Gear
28	X10-040	28	Nut M12	74	X10-084	16	Slide Block
29	X10-041	1	Idler Column Hose	75	X10-085	2	Carriage
30	X10-042	1	Union Tee	76	X10-086	2	Door Guard
31	X10-043	1	Power Unit Hose	77	X10-087	4	Washer 8mm
32	X10-044	1	O-Ring Elbow	78	X10-088	4	Bolt M8 x 30
33	31368-21	1	Power Unit	79	X10-089	2	Front Male Arm
34	X10-045	1	Power Column Hose	80	X10-090	2	Front Intermediate Arm
35	X10-046	2	Long Elbow	81	X10-091	2	Front Female Arm
36	X10-047	2	Cylinder	82	X10-092	2	Bolt M12 x 45
37	X10-048	4	Nut M8	83	X10-093	1	Overhead Weld
38	X10-049	10	Bolt M5 x 8	84	X10-094	2	Synchronizing Cable
39	X10-050	5	Plate-Shutoff Cord Clamp	85	X10-095	6	Nut M16
40	X10-051	4	Bolt M6 x 20	86	X10-096	2	Lock Nut M10
41	X10-052	2	Hose Guide	87	X10-097	1	Lock Release Cable
42	X10-053	2	Hose Guide Nut	88	X10-048	8	Nut M8
43	X10-054	6	Hair Pin Cotter	89	X10-099	4	Washer 20mm

### **IMPORTANT**

Replace all worn or broken parts with **genuine Challenger Lifts, Inc. parts**. Contact your local Challenger Lifts parts distributor for pricing and availability. Call Challenger Lifts, Inc. at **(502) 625-0700** for the distributor in your area.

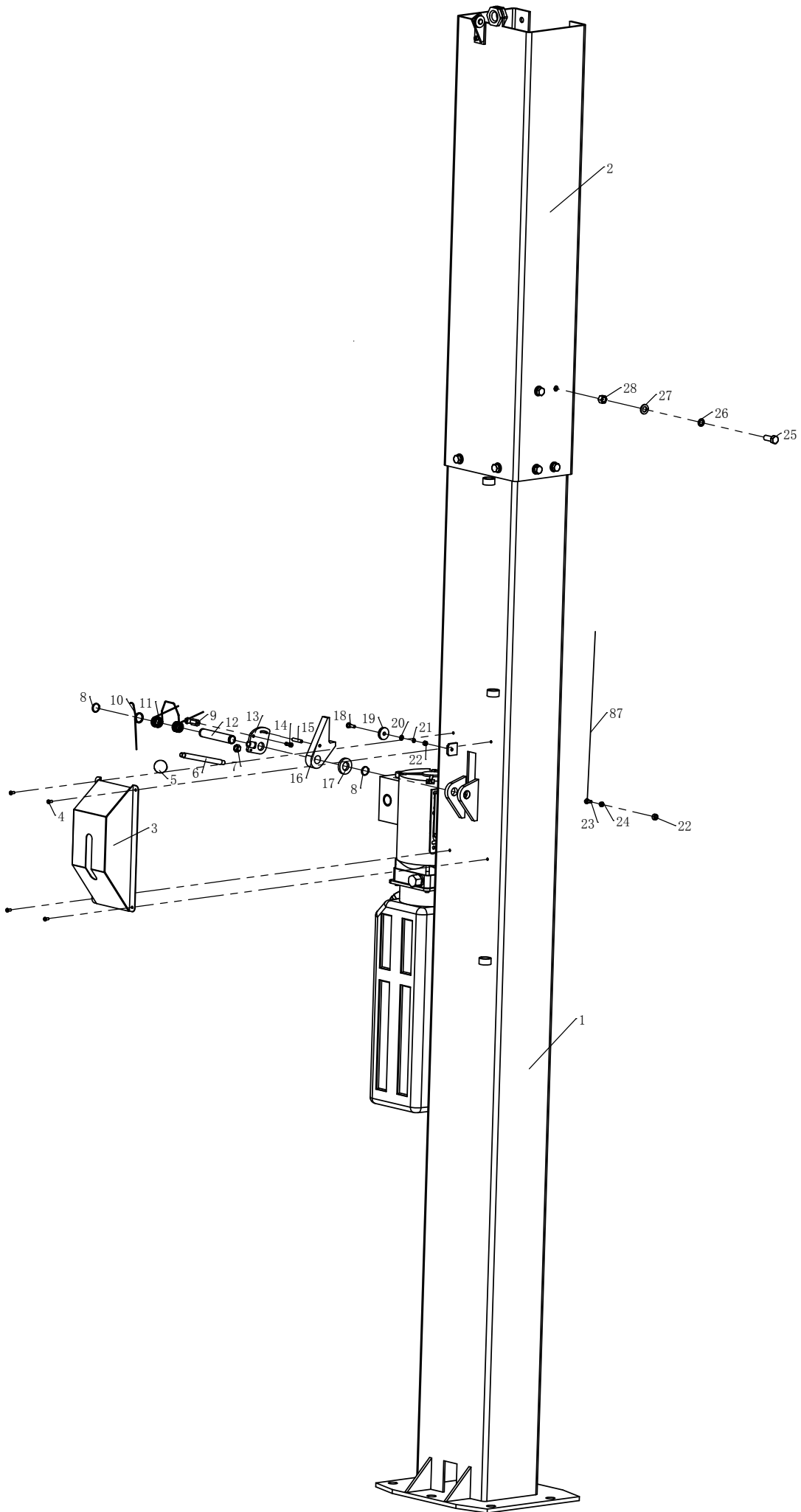

IDLER COLUMN EXTENSION

IDLER COLUMN ASSY

