

COATS®

9500

Electro-Hydraulic Tire Changer For Medium and Large Size Tires



Installation Instructions Operating Instructions Safety Instructions Maintenance Instructions

READ these instructions before placing unit in service KEEP these and other materials delivered with the unit in a binder near the machine for ease of reference by supervisors and operators.

HENNESSY INDUSTRIES, INC.

1601 J. P. Hennessy Drive, LaVergne, TN USA 37086-3565 615/641-7533 800/688-6359

HENNESSY INDUSTRIES INC. Manufacturer of AMMCO®, COATS® and BADA® Automotive Service Equipment and Tools.

Manual Part No.: 8184344 02

Revision: 01/04

Table of Contents

- Safety Instructions**ii-iv
 - Definitions of Hazard Levelsii
 - Operator Protective Equipmentiii
 - Safety Devicesiii
 - Important Safety Instructionsiii
 - Safety Precautionsiii
 - Bead Loosening Safetyiv
 - Demounting & Mounting Safetyiv
 - Inflation Safetyiv
- 1.0 Introduction**1-4
 - 1.1 Use Limitations1
 - 1.2 Notice1
 - 1.3 General Safety Instructions1
 - 1.4 Nomenclature1
 - 1.5 Specifications2
 - 1.6 Dimensions Of The Machine2
 - 1.7 Standard Accessories2
 - 1.8 Optional Accessories3
- 2.0 Carriage Instructions**4
 - 2.1 Uncrating Instructions4
 - 2.2 Installation Area4
- 3.0 Installation Instructions**5
 - 3.1 Electric Installation5
 - 3.2 Motor Rotation Check5
- Operating Instructions**6-17
 - 4.0 Controls6-7
 - 5.0 Mounting And Demounting - General Precautions7
 - 5.1 Locking Rims7
 - 5.2 Demounting Tubeless Truck Tires (Up To 13" Wide)8-9
 - 5.3 Mounting Tubeless Truck Tires (Up To 13" Wide)10-11
 - 5.4 Demounting Duplex And Supersingle Tubeless Truck Tires (Over 13" Wide)12
 - 5.5 Mounting Duplex And Supersingle Tubeless Truck Tires (Over 13" Wide) ..12-13
 - 5.6 Demounting Tires From Multi-Piece Rim/Wheel Assemblies14
 - 5.7 Mounting Tires Onto Multi-Piece Rim/Wheel Assemblies15
 - 5.8 Demounting Tractor And O.T.R. Wheels With One-Piece Rims15-17
 - 5.9 Mounting Tractor And O.T.R. Wheels On One-Piece Rims17
- 6.0 Maintenance**18
- 7.0 Moving The Machine**18
- 8.0 Storing The Machine**18
- 10.0 Trouble Shooting**19

Safety Instructions



Failure to follow danger, warning, and caution instructions may lead to serious personal injury or death to operator or bystander or damage to property. Do not operate this machine until you read and understand all the dangers, warnings and cautions in this manual. For additional copies of either, or further information, contact:



Hennessy Industries, Inc.
 1601 J.P. Hennessy Drive
 LaVergne, TN 37086-3565
 (615) 641-7533 or (800) 688-6359
www.ammcoats.com

Definitions of Hazard Levels

Identify the hazard levels used in this manual with the following definitions and signal words:

DANGER



Watch for this symbol:
 It Means: Immediate hazards, which will result in severe personal injury or death.

WARNING



Watch for this symbol:
 It Means: Hazards or unsafe practices, which could result in severe personal injury or death.

CAUTION



Watch for this symbol:
 It Means: Hazards or unsafe practices, which may result in minor personal injury or product or property damage.

SAFETY ALERT



Watch for this symbol! It means BE ALERT! Your safety, or the safety of others, is involved!

Operator Protective Equipment

Personal protective equipment helps make tire servicing safer. However, equipment alone does not take the place of safe operating practices. Always wear durable work clothing during tire service activity. Loose fitting clothing should be avoided. Tight fitting leather gloves are recommended to protect operator's hands when handling worn tires and wheels. Sturdy leather work shoes with steel toes and oil resistant soles should be used by tire service personnel to help prevent injury in typical shop activities. Eye protection is essential during tire service activity. Safety glasses with side shields, goggles, or face shields are acceptable. Back belts provide support during lifting activities and are also helpful in providing operator protection. Consideration should also be given to the use of hearing protection if tire service activity is performed in an enclosed area, or if noise levels are high.

Safety Devices

This machine has several protectors to prevent compression or crushing hazards to body areas. Keep these devices properly maintained and do not disable or in any way shortcut the safety controls and operations.

There is a micro-switch protection under the chuck arm to prevent compression.

The rotation speed of the chuck has been limited to a maximum of 8 rpm to prevent dragging or en-trapping hazards.

There is an emergency button on the portable control unit.

Important Safety Instructions



Only properly trained personnel should service tires on the 9500. Read all safety and operating instructions thoroughly before using the tire changer.

ALWAYS remove all wheel weights and the valve core to deflate the tire before servicing.

ALWAYS cover the electric motor and switch box before hosing down the tire changer. Be sure water does not enter the motor or switch box.

ALWAYS disconnect the electric power and air supply before attempting any maintenance.

ALWAYS keep all working surfaces clean and free of tire lube buildup.

ALWAYS be aware of what each person is and will do before attempting any two-person operation.

Safety Precautions

A . Before servicing any tires, wheels or rims all personnel should receive thorough training for the proper servicing of truck tires, wheels and rims. Consult with your local city, country state, and national safety and health administrators to receive clarification of any publications available governing this serious matter.

B . During the use and maintenance of the machine it is mandatory to comply with all laws and regulations for accident prevention.

C . The electric power source must have a ground cable and the ground cable of the machine (yellow and green) must be connected to the ground cable of the power source.

D . Before any maintenance or repairs are accomplished the machine must be disconnected from the electric supply. The unit should only be serviced by a qualified service technician.

E . Never wear ties, chains or other loose articles when using, maintaining or repairing the machine. Long hair is also dangerous and should be kept under a hat. The user must wear proper safety attire, i.e. gloves, safety shoes and glasses.

F . Maintain all electric cords in good repair.

G . Keep safety features in place and in working order.

H . Keep working area clean. Cluttered areas invite accidents.

I . Avoid dangerous environments. Don't use power tools or electrical equipment in damp or wet locations, or expose them to rain.

L . Nobody should be allowed to stand next to or near the wheel, when mounting/demounting a tire or clamping a wheel.

M . Keep the work area well lighted.

N . Properly anchor the machine to the floor.

Bead Loosening Safety

NEVER place any part of your body between the bead loosener disc and the tire/wheel, severe bodily injury may result.

NEVER place anything between the bead loosener disc and the tire/wheel as damage may result.

NEVER allow the bead loosener to contact the wheel, wheel damage may occur.

Demounting & Mounting Safety

NEVER stand on the working table while demounting or mounting a tire, as personal injury may result.

ALWAYS keep hands, feet, and other objects away from moving parts while the machine is turned on.

ALWAYS place the narrow bead seat to the outside when clamping. Failure to demount the tire from the narrow bead seat side may cause damage to the tire beads.

ALWAYS apply an approved rubber lubricant to rim flanges and both tire beads before demounting or mounting and seating the beads. *NEVER* use antifreeze, silicone, or petroleum base lubricants.

ALWAYS clean and inspect the wheel before servicing.

NEVER mount a tire on a damaged or rusty wheel. Wheel damage or rust may cause tire or wheel failure during inflation. Explosion from failure may result in severe injury or death of the operator and bystanders.

ALWAYS be sure the bead opposite the tool is in the drop center before rotating the tire when demounting or mounting to avoid damage to the tire beads.

Inflation Safety

ALWAYS follow all applicable Local, State, and Federal Codes, Rules, and Regulations; such as the Federal OSHA Standard Number 1910.177.

NEVER seat beads or inflate a tire on the tire changer. This tire changer is not designed as a safety device or stand for bead seating or inflation.

ALWAYS use an approved inflation chamber or inflation cage.

The following safety instructions are for one piece wheels only. Refer to the manufacturer's or R.M.A. procedures for multipiece wheels.

ALWAYS use an approved inflation chamber or inflation cage equipped with a grip chuck and a remote inflation gauge and valve. **DO NOT OVER INFLATE!** Tire or wheel failure during and after inflation may result in an explosion capable of causing severe injury or death.

ALWAYS inflate the tire to manufacturer's recommended cold operating pressure.

NEVER reinflate a tire that has been run underinflated or flat without first demounting the tire and checking for wheel and tire damage.

ALWAYS inspect the tire interior for loose or broken cords, cuts, penetrating objects, and other damage to the carcass. Discard tires that cannot be properly repaired.

NEVER rework, weld, heat or braze wheels.

NEVER strike the tire or wheel with a hammer.

ALWAYS be sure the tire diameter exactly matches the wheel diameter.



Tire failure under pressure can be hazardous. Place the wheel inside an approved inflation chamber or cage before inflating. Use an approved remote inflation valve, hose, and gauge. ALWAYS wear safety goggles for eye protection. Do not stand beside the wheel or cage during inflation. Keep hands and other parts of the body out of the cage during inflation. Observe the tire pressure frequently. Do not exceed the manufacturer's recommended maximum inflation pressure. Failure to follow these instructions may cause the tire and rim to separate with tremendous force, resulting in serious personal injury or death.

1.0 Introduction

Congratulations on purchasing the COATS® 9500 Electro-Hydraulic Tire Changer.

This tire changer is designed for ease of operation, safe handling of rims, reliability and speed.

With a minimum of maintenance and care, your tire changer will provide many years of trouble-free operation.

Instructions on use, maintenance and operational requirements of the machine are covered in this manual.



Store this manual in a convenient place for future reference. Read this manual thoroughly before using the machine.

1.1 Use limitations

The COATS model 9500 tire changer is intended to be used as a device to demount and mount tubeless truck tires with the following specifications:

Maximum Tire Diameter: 90 1/2 inches (2300 mm)
Maximum Tire Width : 43 inches (1100 mm)

This device shall be used in the application for which it is specifically designed. Any other use shall be considered as improper, and not WITH THE SPECIFICATIONS OF THIS UNIT. In particular, this device is not suitable to inflate tires. Inflation of tires shall be carried out in an approved inflation safety cage. The manufacturer shall not be considered liable for possible damage caused by improper, wrong or non-SPECIFIED use.

1.2 Notice

This manual is a part of the product. Read carefully the warnings and instructions of this manual since they provide important information concerning safety and maintenance.

1.3 General Safety Instructions

Any misuse or modification of this device or of its parts or components not previously authorized by the manufacturer relieves the manufacturer from any damage consequent or related to the above mentioned misuse.

No modifications should be made without consulting COATS®. Removing or bypassing any safety devices or warning labels of the machine is a violation of the safety regulations.

The use of this device is allowed only in locations with no explosion or fire hazards, consistent with state and local fire codes.

This equipment is designed to use original or manufacturer supplied spare parts and accessories only.

The installation shall be carried out only by qualified personnel and within the scope of the instructions provided in this manual.

Check for possible dangerous conditions during the operation of the machine. If such a case exists stop the machine immediately. In case a defective functioning condition stop using the machine, immediately and call the authorized distributor for assistance.



All electrical connections shall be performed by a licensed electrician. All service must be performed by an authorized service technician.

1.4 Nomenclature

Before installing and using the tire changer it is suggested that you become familiar with the nomenclature of the machine's components (fig.1).

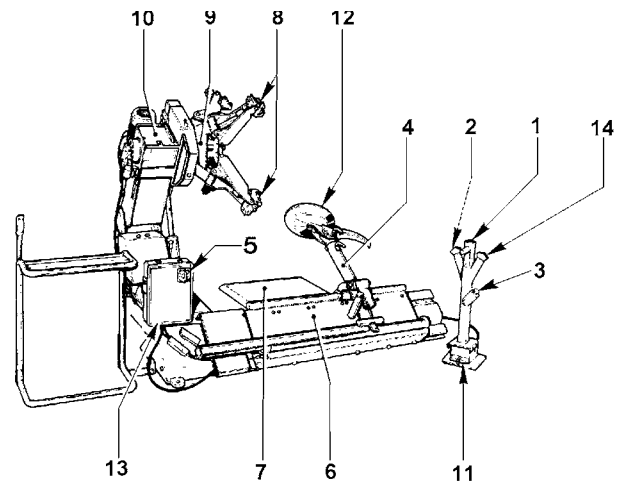

Fig.1

- 1 - 8 Position Switch
- 2 - Chuck Switch
- 3 - Emergency Stop
- 4 - Tool Holder Arm
- 5 - Main Switch
- 6 - Tool Holder Carriage
- 7 - Foot Board
- 8 - Jaws
- 9 - Self-centering Chuck
- 10 - Chuck Arm
- 11 - Chuck Rotation Control Pedal
- 12 - Mount/Demount Tool
- 13 - Electric Cabinet
- 14 - Tool Holder Arm & Release

1.5 Specifications

Electro-hydraulic tire changer for tubeless truck tires.

Weight with Standard Acc.	2079 lbs. (945 kg)
Electric Specifications	220VAC, 3Ph, 60Hz, 22A
Hydraulic Motor Power	2 HP (1.5 kW)
Chuck rotation Motor Power	3-4 HP (2.2 - 3 kW)
Chuck Capacity	14" - 56"
Max. Tire Diameter	90 1/2 inches (2300 mm)
Max. Tire Width	43 inches (1100 mm)
Max. Chuck Torque	2268 ft./lbs. (3100 mm)
Clamping Power	13,513 lbs. (60 kN)
Chuck Rotation Speed	4 - 8 rpm
Acoustic Pressure	<70dBA

1.6 Dimensions Of The Machine

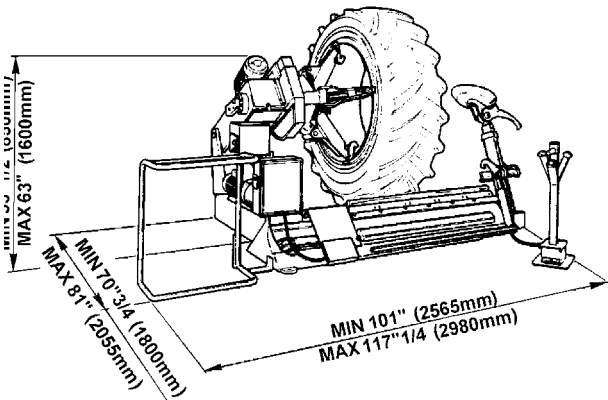

Fig.2

1.7 Standard Accessories

#870001418 Short Tire Tool

#874004461 Long Tire Tool

#874002354 Bead Pushing Lever

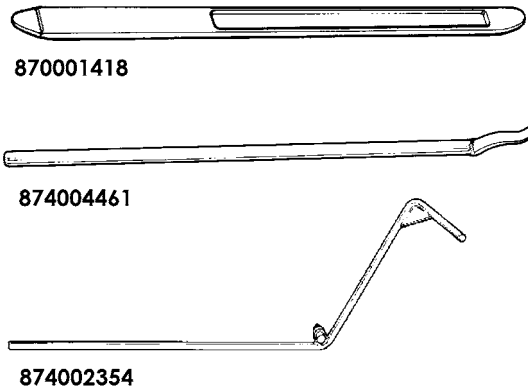

Fig.3

#874009472 Mounting Clamp (fig.4).

To hold the bead when mounting tires on steel rims. Instructions for use is in section 5.3.

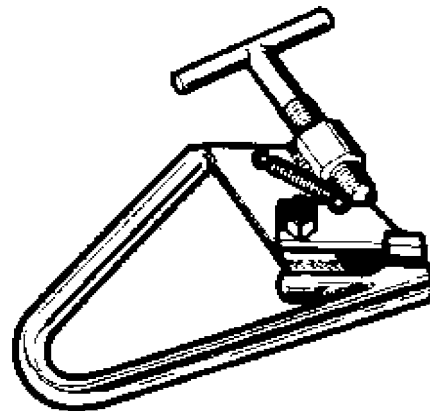

Fig.4

1.8 Optional Accessories

#874021852 Clamp for Light-Alloy Rims (fig.5).

To hold the bead when mounting tires on light-alloy rims. Instructions for use is in section 5.3.

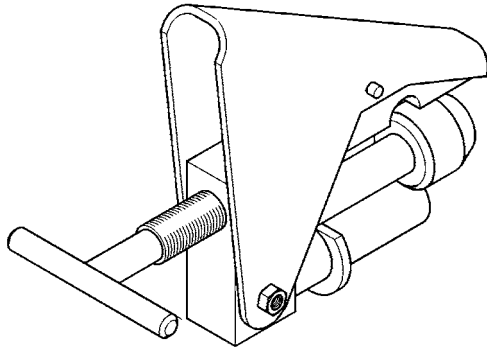

Fig.5

#874007611 O.T.R. Clamp (fig.6)

Useful when breaking the bead from the rim on multi-piece wheels (O.T.R.).

Instructions for use is in section 5.6.

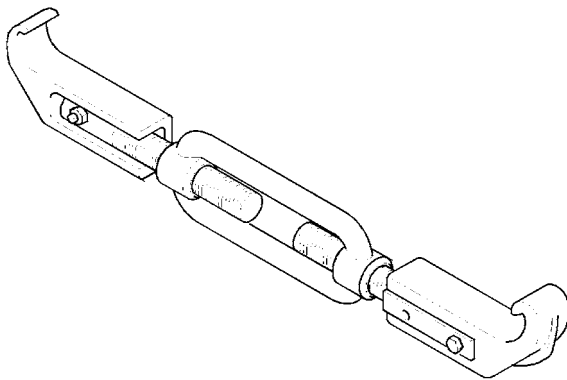

Fig.6

#874008257 Protectors for Alloy Rims (fig.7).

Suitable for rims with a center hole of 220 and 280 mm.

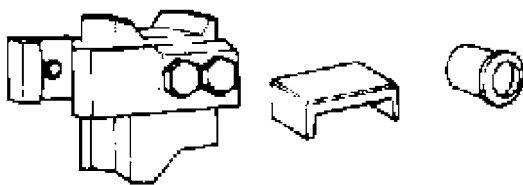

Fig.7

#874008264 Protectors for Alloy Rims (fig.8)

Suitable for rims with a center hole of 280 mm only.



Fig.8

#874014974 Tubeless Roller (fig.9).

Facilitates mounting and dismounting tubeless tires up to 13" wide.

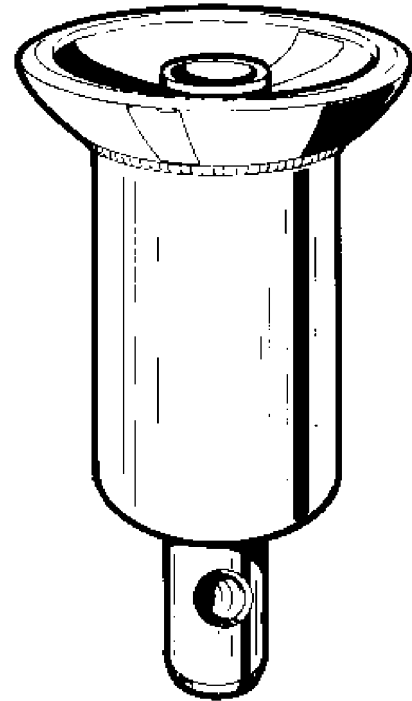

Fig.9

#874019161 Extensions for 56" (fig.9/A).

Necessary when clamping rims without flange and with a diameter exceeding 44".

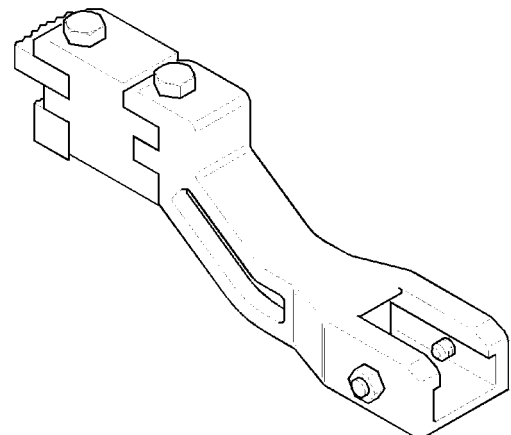

Fig.9/A

2.0 Carriage Instructions

The machine is crated in a wooden box of appropriate strength.

The box is mounted on a pallet.

Handling of the machine must be performed with an appropriate lifting device (fork lift) (fig.10).

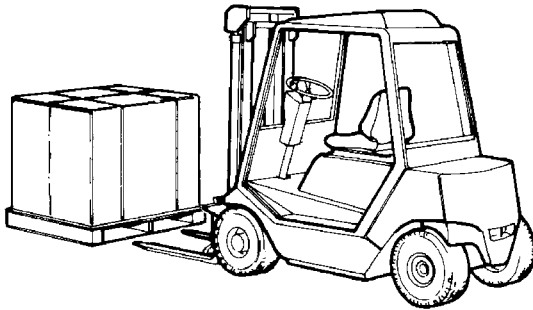

Fig.10

2.1 Uncrating Instructions



Always wear gloves when uncrating the machine to prevent scratches, abrasions, or cuts due to the contact with packing materials.

Uncrate the machine paying attention when removing the nails or during any other operation which may be hazardous.

After removing the crate, check for any visible damage to the machine and its components.

If in doubt, call qualified personnel for assistance.

The packing materials (plastic bags, polystyrene, nails, screws, wood etc.) must be properly disposed of.

Place the above-mentioned materials into a trash container and dispose per local regulations.

2.2 Installation Area

Install the machine in a covered and dry area.

The installation of the machine requires a free space of at least cm 16' 5" x 16' 5" (500cm x 500cm) (fig.11).

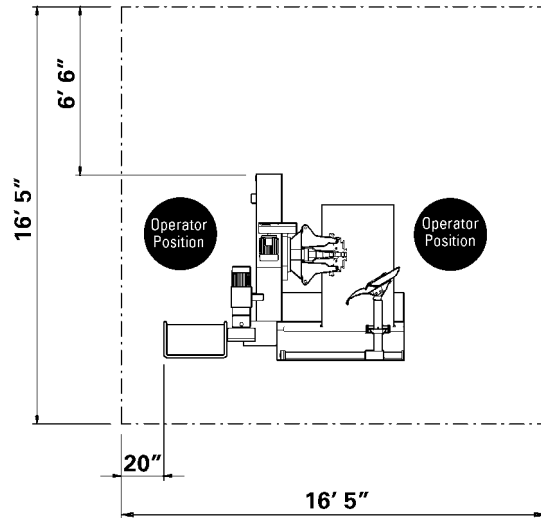

Fig.11

Make sure that from the operating position (fig. 11) the user can see all of the machine and the surrounding area.

Only authorized operators of the equipment should be in the work area. Keep the work area clean and clear of objects which may create possible hazards.

It is the responsibility of the facility owner to properly designate work areas and areas where by-standers are not permitted.

Install the machine on a horizontal floor, preferably even. Do not install the machine on a sinking or irregular floor.

In case the machine is installed on a raised floor or on a service vehicle, the floor must have a capacity of at least (330 lbs. x sq. ft.). Please contact COATS directly at 1-800-688-9240 to discuss options and other precautions that may apply.

The machine must be secured to the floor through the holes provided in the cabinet. Expansion screws (1/2" x 4 3/4"), or bolts (1/2" x 3 1/8") shall be used.

Drill (1/2") holes in the floor flush with the holes provided in the cabinet.

Place the lags into the holes drilled in the floor and move the machine so that the holes of the cabinet are flush with the holes in the floor.

Tighten the screws to (50 ft. lbs.).

3.0 Installation Instructions

To install the machine proceed as follows:

A. Before raising the machine, ensure that the chuck is completely closed, that the chuck arm is lowered and the tool holder carriage is all the way in (Fig.12).

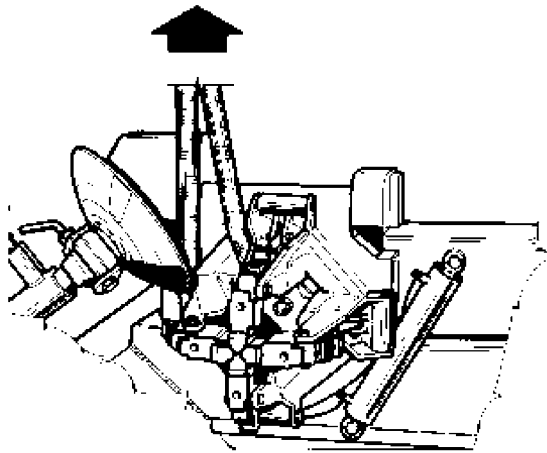

Fig.12

B. Remove the screws that secure the machine to the pallet.

Lift the machine only with the two lifting lugs with a belt or rope of appropriate length and strength.



Do not swing the machine when lifted.



Do not cut the remote unit cord when lowering the machine to the ground.

3.1 Electric Installation

All electrical connections shall be performed by a licensed electrician. All service must be performed by an authorized service technician.

Check on the plate of the machine that the electrical specifications of the power source are the same as the machine.

The machine uses 220VAC, 60 Hz, 3Ph, 22 Amp.

Electrical specifications are clearly marked on a label at the end of the electric cord.

Before connecting the machine to the power source, check that the power supply has an efficient grounding system.

Connect the electric cord of the machine with a correctly rated plug.

There should be less than 1 Ω between the ground pin and earth ground.

Note: The outlet installation must be verified by a licensed electrician before connecting the tire changer.

Note: The yellow with green wire in the cord is the grounding wire.

Never connect the grounding wire to a live terminal.

Check that the power supply has an automatic circuit breaker with a differential circuit set at 30 mA.

The electric motor operates in a wide voltage range (plus 10% - minus 7%) and frequency range (50 or 60 cycles) and has a class of insulation suit-able for hot and moist climates.

3.2 Motor Rotation Check

Once the machine is hooked-up, turn the machine on using the on/off switch.

Important: Ensure that the rotation direction of the pump is the same as indicated by the arrow on the motor cover.

If not, reverse any two phase cables on the plug (i.e. Reverse the brown and the blue cable).



Any damage caused by the non-application of the above instructions shall not be covered by the manufacturer and will void the warranty.

Operating Instructions

4.0 Controls

Before operating the machine ensure that you thoroughly understood the operation and function of all the controls.

1. To turn the machine on, rotate the ON/OFF switch to position 1 and press the reset button: The pump motor starts turning and remains in operation until the machine is turned off. The power required is minimum when the hydraulic cylinders are not in use.

Note: Turn the machine OFF after every mounting or demounting operation, if the time before the next operation is longer than 5 minutes.

2. Press the chuck rotation pedal to the right: The chuck rotates clockwise. Press the other pedal: The chuck rotates counterclockwise.

3. Operate the control (#1 fig.13) to position **A**: The chuck arm moves upwards.

Operate the control (#1 fig.13) to position **B**: The chuck arm moves downward.

4. Operate the control (#1 fig.13) to position **C**: The tool holder carriage moves to the right.

Operate the control (#1 fig.13) to position **D**: The tool holder carriage moves to the left.

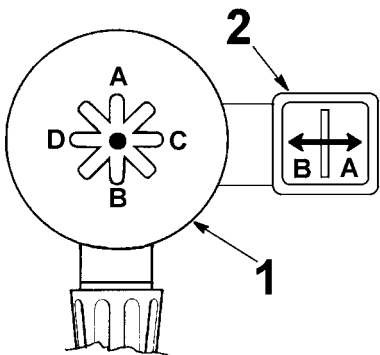

Fig.13

5. Operate the control (#2 fig.13) to position **A**: The tool holder arm moves to the right.

Turn the switch to position **B**: The tool holder arm moves to the left.

6. By operating the controls in one of the diagonal positions, the two adjacent movements are achieved simultaneously. This operation affords considerable time saving in the intermediate operations, but requires a little practice.

Note: If one of the two hydraulic movements reaches the end of its course, the speed of the other movement is appreciably reduced: Interrupt the control engaged and operate only the desired movement in order to get normal operating speed.

7. To lift the tool holder arm, depress the pedal (#1 .

14) and hold handle (#2 fig.14).The arm is balanced by a spring-loaded mechanism and the effort required is minimum.



If the tool holder arm is not correctly locked in the working position serious injury may result to the operator and to the machine.

When locking the arm into working position be sure to use enough force to ensure a proper lock. The heavy metal construction can easily absorb the force.

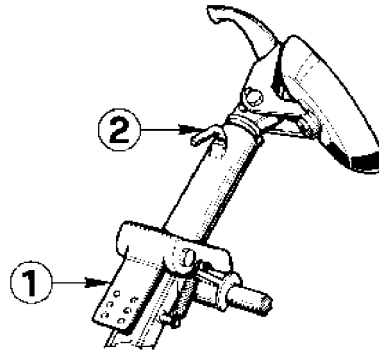

Fig.14

8. To turn the tool remove pin (#2 fig.14).



Be sure that the lock pin is properly fitted.

9. To open and close the chuck, operate the appropriate control (#1 fig.15).



When opening the chuck ensure that the jaws do not contact or hit other parts of the machine.

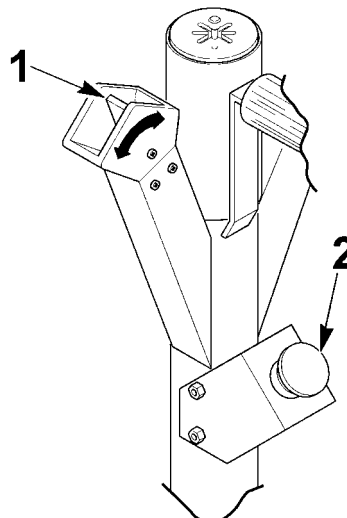

Fig.15

10. Press the emergency STOP button (#2 fig.15): This renders all controls inoperative.

Turn the emergency knob counterclockwise and press the reset button located on the electric cabinet to resume normal working conditions.

5.0 Mounting and Demounting - General Precautions



Before mounting a tire on a rim, pay attention to the following:

A. The rim and all its parts must be clean and in good condition: If necessary clean and paint it after removing all wheel-weights, including tape weights inside the rim.

B. The tire must be clean and dry, without any damage to the bead and the carcass.

C. Replace the rubber valve stem with a new one or replace the "o" ring if the valve stem is made of metal.

D. If the tire requires a tube or a flap, make sure the tube is dry and in good condition.

E. Lubrication is necessary to mount the tire correctly and get a proper centering. Be sure you are using approved lubricant only.

F. Make sure the tire is the correct size for the rim.

5.1 Locking Rims

Lift the tool holder arm and move the tool holder carriage all the way out.

Put the wheel in vertically and roll it on the foot board. Be sure to use alloy adapters when applicable.

Attention! The drop center of the rim (when it exists) must be kept towards the outside of the machine (fig.16).

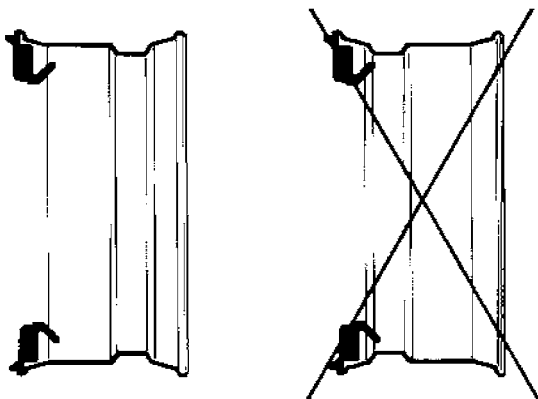

Fig.16



If the wheel is very heavy be sure to use a suitable external lifting device (i.e. fork lift, crane etc.).

Close the jaws of the chuck and move the chuck approximately to the center of the rim. Move the foot board toward the chuck and move the chuck up-down while opening the chuck arms until the rim is clamped properly (fig.17).

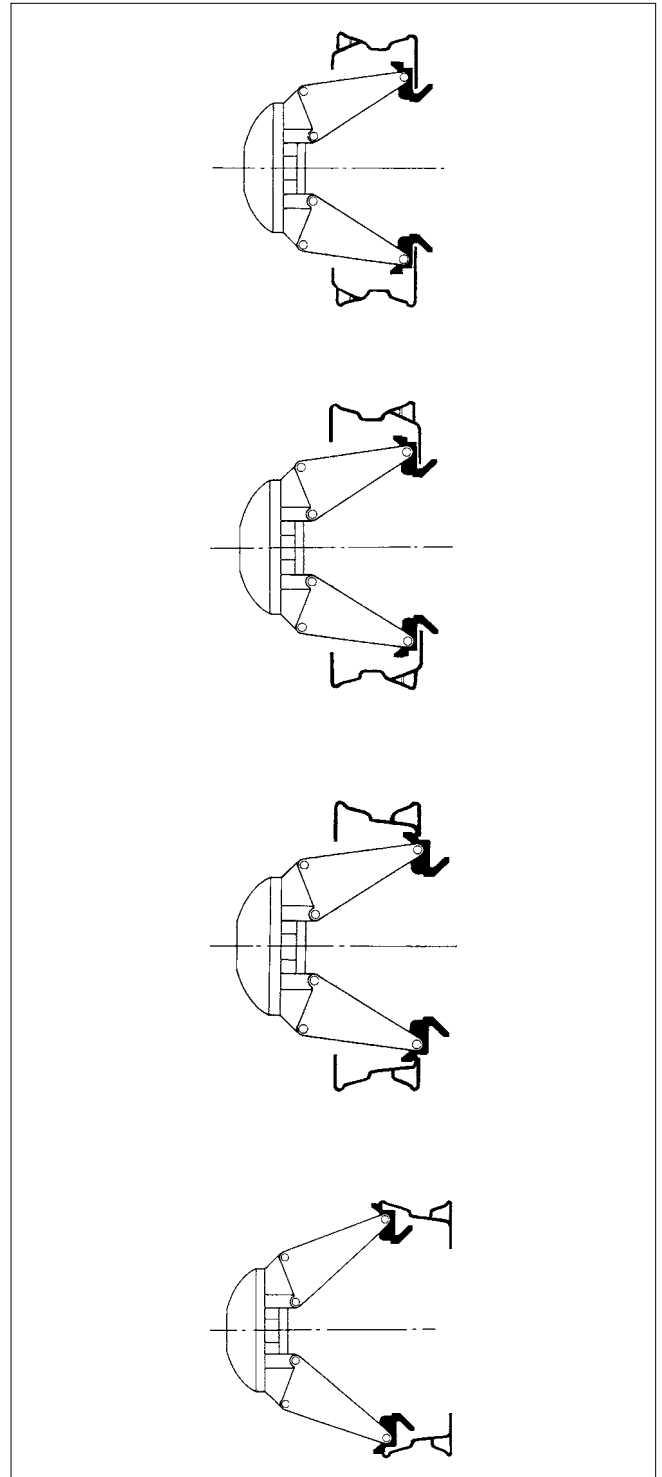

Fig.17

5.2 Demounting Tubeless Truck Tires (Up to 13" Wide)

The tubeless truck tires are mounted on drop-center rims with a conical base. It is possible to demount these tires simply by pressure, with a proper lubrication (fig.18).

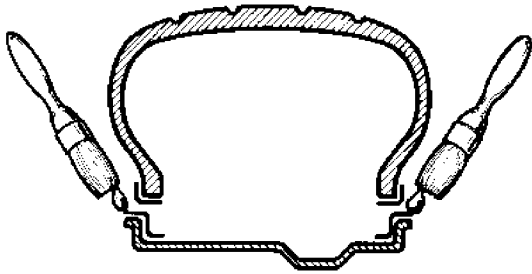

Fig.18

1. Remove all wheel-weights from the rim. Remove the valve stem or core and deflate the tire.

2. Position the bead loosener disc or tubeless roller (option) as shown in fig.19, fig.20.

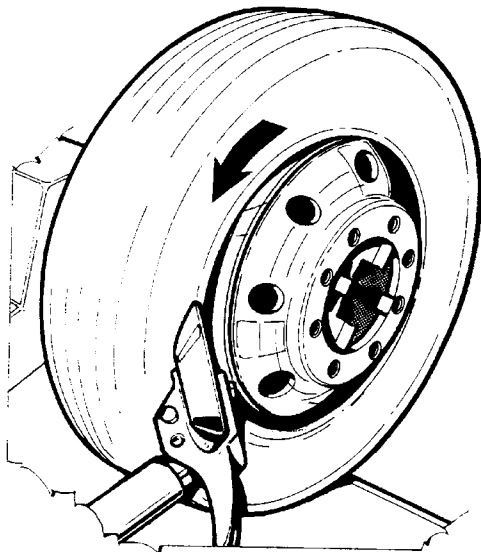

Fig.19

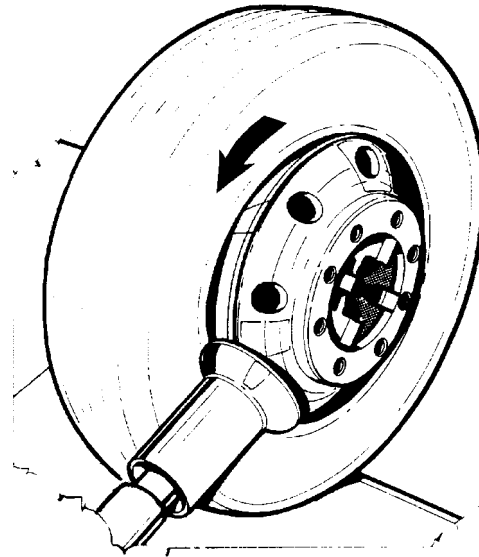

Fig.20

3. Lift or lower the chuck so that the bead loosener disc or tubeless roller remains close to the rim edge. Turn the chuck counterclockwise and at the same time shift the tool holder carriage step-by-step toward the inside to demount the tire.

Continue to turn the chuck and lubricate the bead and the rim liberally with an approved lubricant.



Use only approved lubricants for tires and wheels.

4. Raise the tool holder arm to the rest position.
5. Move the tool holder arm all the way in. Lower the arm and secure. Bring the tool in contact with the inner bead.
6. Loosen the inner bead as described in point #3 above.

7. Continue rotating the chuck, moving tool holder carriage towards the outside until the beads are demounted from the rim (fig.21 and fig.22)

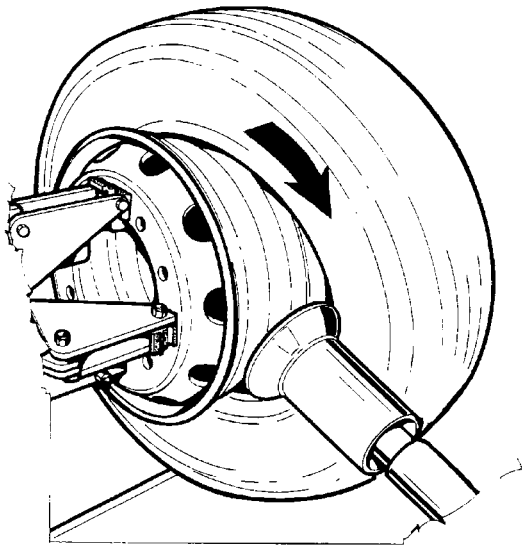

Fig.21

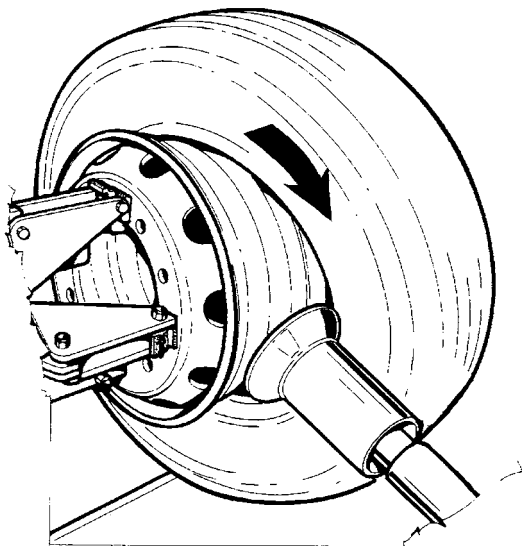
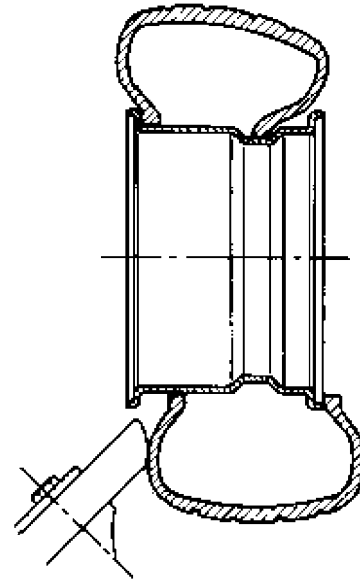

Fig.22



Ensure that the outer bead slides into the drop center opposite to the tool, otherwise the demounting operation is impossible.



8. Move to the front of the tire and hold it with both hands in the last part of demounting operation to prevent the tire from falling or rolling away out of control (fig.23).

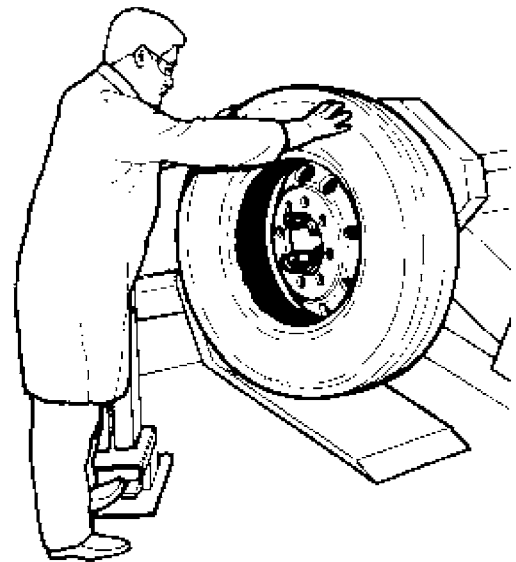

Fig.23

5.3 Mounting Tubeless Truck Tires (Up to 13" Wide)

1. Liberally lubricate the entire inner surface of the rim and the tire beads. Attach the mounting clamp (fig.24) to the outer rim flange with the valve at 11 o'clock and the clamp at 12 o'clock.

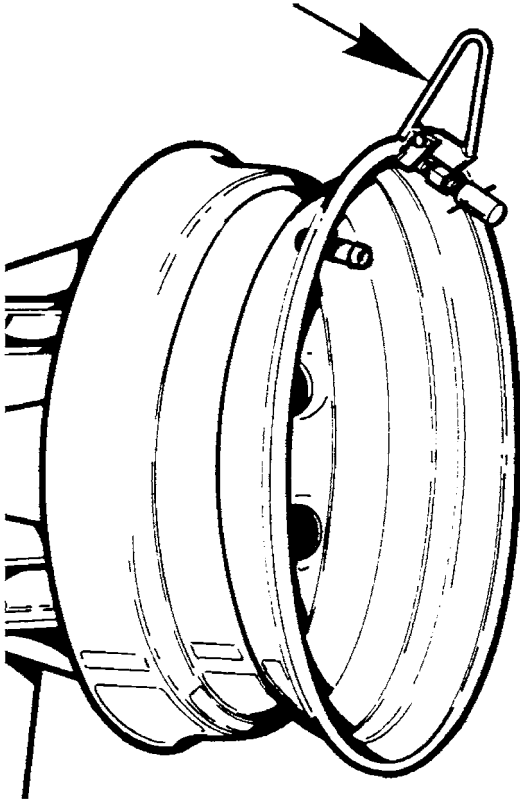

Fig.24

If the rim is made of a light-alloy, the rim shape may not allow the standard mounting clamp to be attached. In such a case use the light-alloy mounting clamp (option). The clamp can be used as shown in fig.25 or 26.

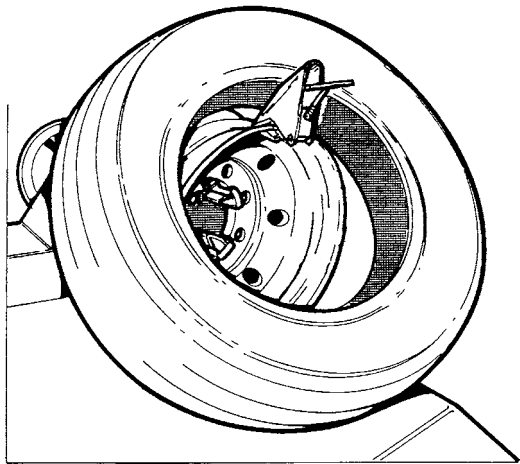

Fig.25

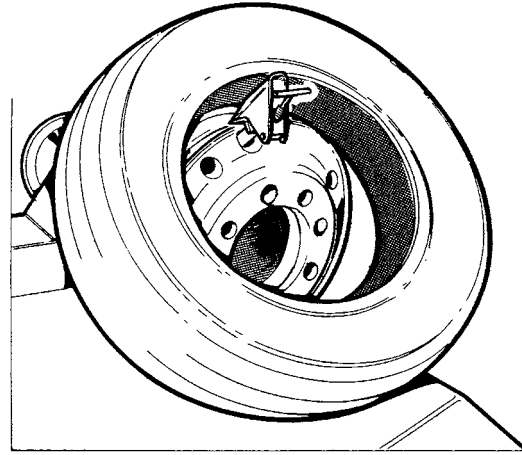

Fig.26

2. Move the chuck arm all the way down. Roll the tire on the foot board and hang it onto the mounting clamp (fig.27).

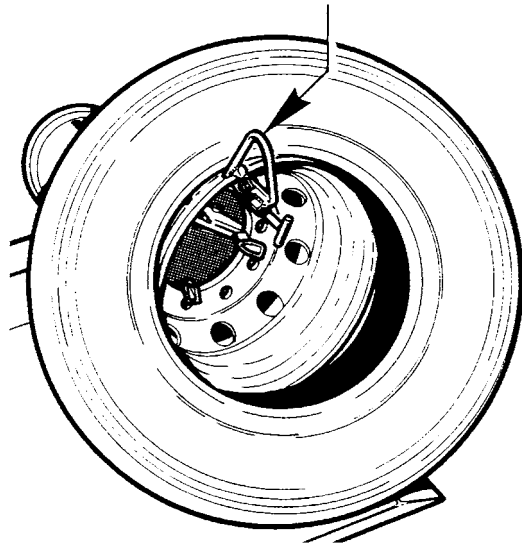

Fig.27

3. Lift the chuck arm and position the mounting hook or tubeless roller approximately 1.5 cm (1/2") to the inside of the rim edge and approximately 1.5 cm (1/2") away from the rim edge (fig.28).

The mounting clamp is at approximately 11 o'clock.

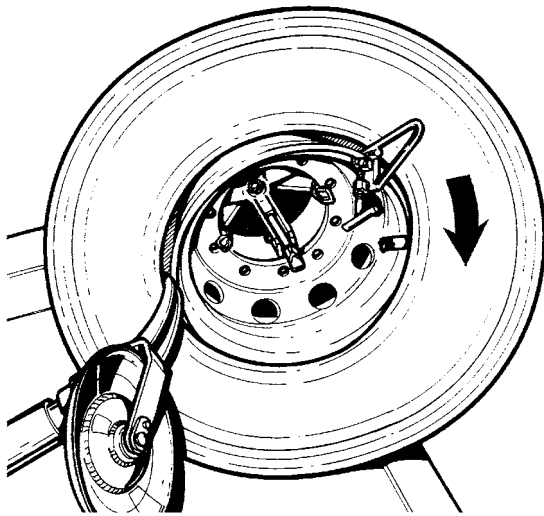

Fig.28



Never use hand pressure to hold the tire onto the rim as personal injury may result.

4. Turn the chuck clockwise until the tire is completely mounted (fig.29).

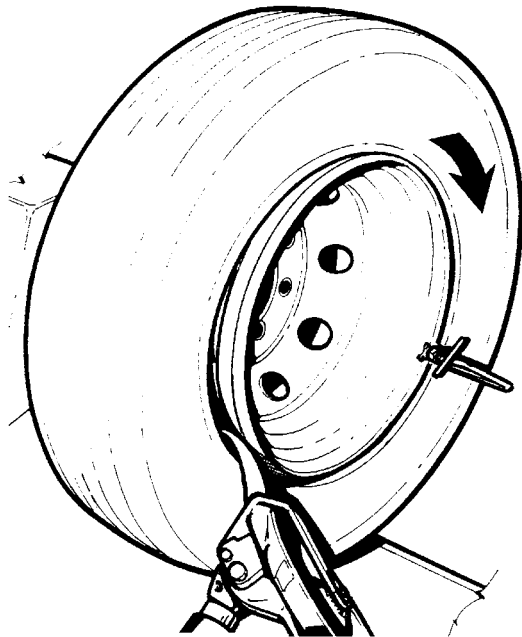
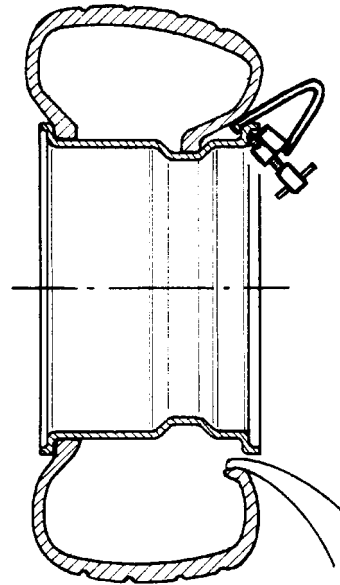

Fig.29



Ensure that the outer bead moves into the drop center when the clamp is opposite to the tool.



Stop the chuck before one complete turn is made to avoid serious damage to the mounting clamp and to the rim.



Do not inflate the tire on the machine. This machine is not an inflation device.

For inflation place the wheel in an approved inflation restraint device. Refer to OSHA standard number 1910.177.

5.4 Demounting Duplex and Supersingle Tubeless Truck Tires (Over 13" Wide)

Note: For this operation the mount/demount tool is required.

1. Loosen the bead of the tire as described in #5.2.1-5.2.6.

2. For this type of tire it is not possible to demount both beads at the same time with the roller as described in #5.2.7.

Engage the hook of the mount/demount tool between the bead and the rim.

3. Lift the chuck arm enough to clear the hook 1" - 1 1/2" from the rim flange. Move the mount/demount tool towards the outside. This will allow you to place the long bar in between the bead and the rim flange for necessary prying (fig.30).

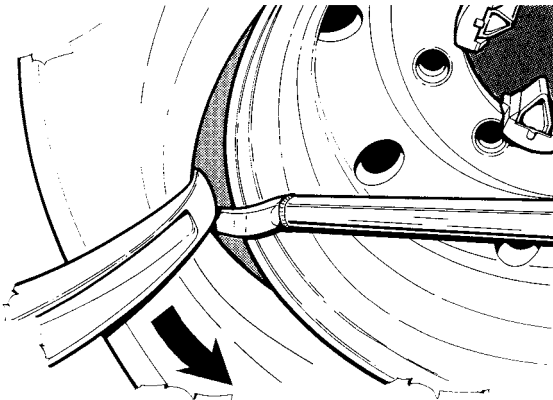

Fig.30

4. Rotate the chuck counterclockwise until the outer bead is completely demounted (fig.31).

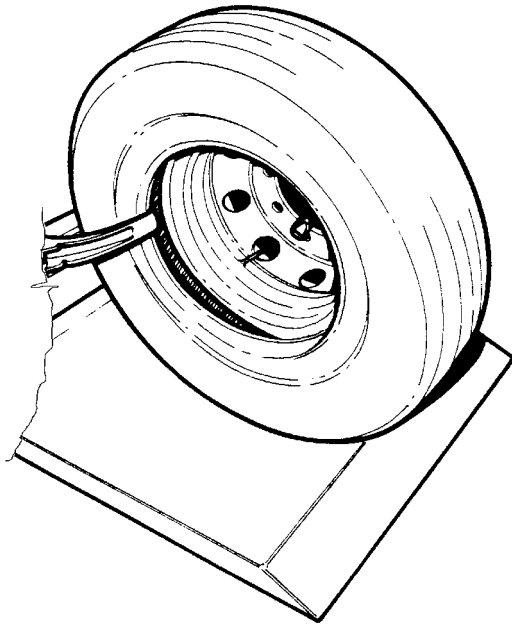

Fig.31

5. Demount the inner bead with the bead breaker disc, as described in #5.2.7. (fig.32).

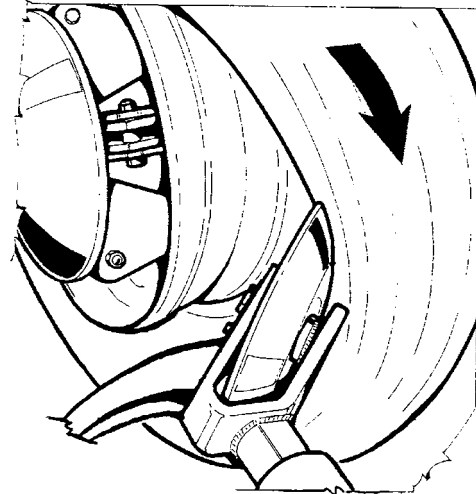

Fig.32

5.5 Mounting Duplex And Supersingle Tubeless Truck Tires (Over 13" Wide)

1. Hang the inner bead of the tire on the mounting clamp (fig.33).

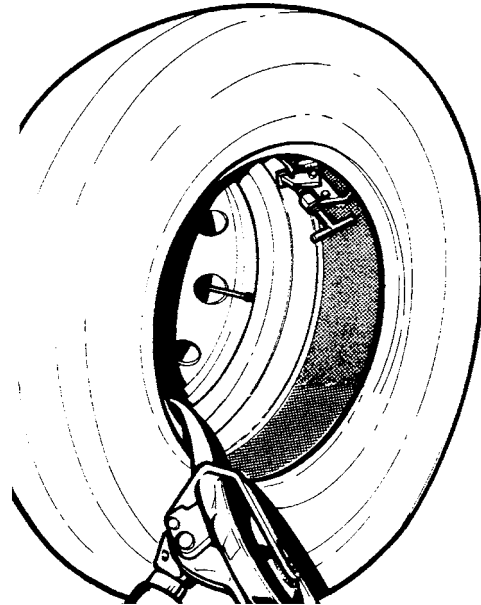

Fig.33

2. Position the mounting hook about 3/4" (1.5 cm) to the inside of the rim edge and 1/2" (1 cm) away radially.

3. Rotate the chuck clockwise. Normally less than 1/4 of a revolution is sufficient to mount the first bead (fig.34).

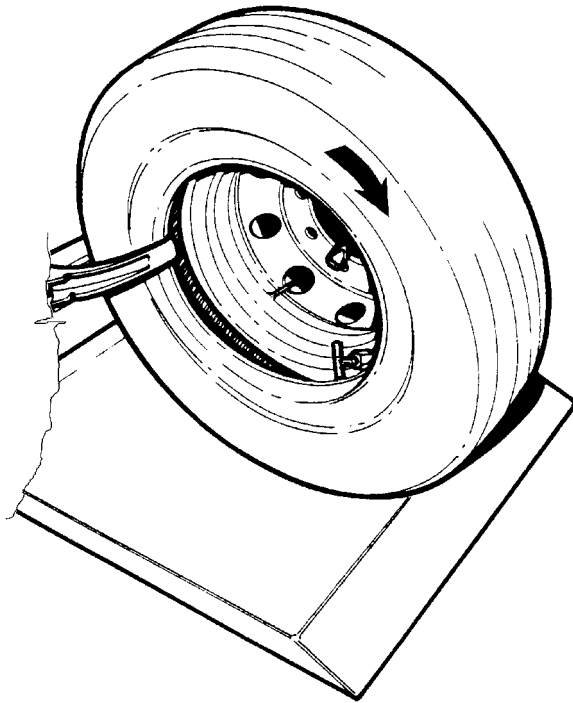

Fig.34

4. Re-attach the mounting clamp to the rim flange with the valve forward of the mounting clamp (fig.35).

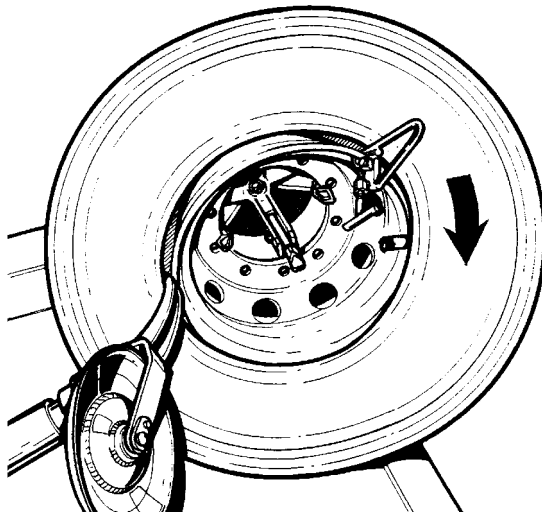

Fig.35

5. Rotate the chuck clockwise until the tire is completely mounted.

Ensure that outer bead descends into the drop center when the clamp is opposite to the mount/demount tool (fig.36).

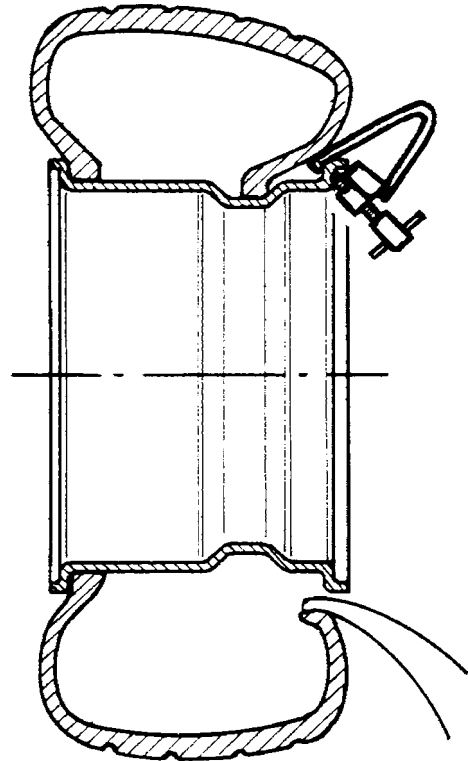

Fig.36



Never use hand pressure to hold the tire onto the rim.



Stop the chuck before one complete turn is made to avoid serious damage to the mounting clamp and to the rim.



Do not inflate the tire on the machine. This machine is not an inflation device.

For inflation place the wheel in an approved inflation restraint device. Refer to OSHA standard number 1910.177.

5.6 Demounting Tires From Multi-Piece Rim/Wheel Assemblies (Tube Type Tires)

The multi-piece rim/wheel assembly can be in two or more pieces (fig.37).

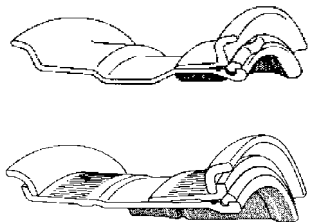

Fig.37

1. Remove all wheel-weights from the rim. Remove the valve stem or core and deflate the tire completely.

2. Position the tool close to the rim edge (fig.38). When the lock ring is stuck to the tire bead, (on the O.T.R. tires) to loosen the bead, it is necessary to hold the ring to the rim with the appropriate clamp #874007611 (optional accessory).

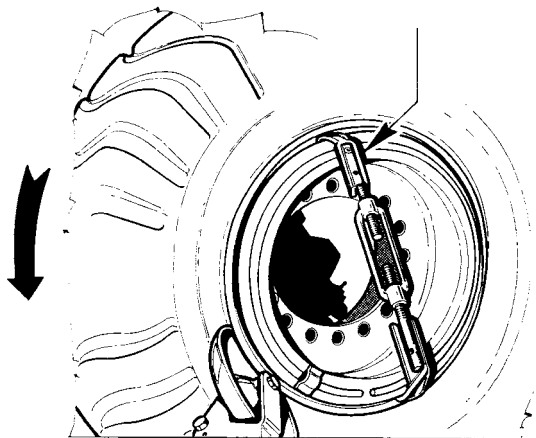

Fig.38

3. Turn the chuck counterclockwise and loosen the bead as described in #5.2.1.-5.2.3. Do not lubricate.

4. To remove the lock ring, squeeze one edge with the proper bar and place the bead loosener disc as shown in fig.39.

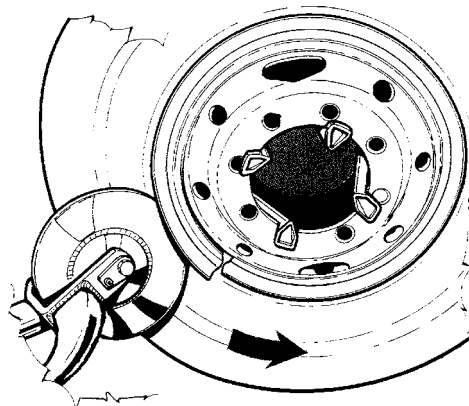

Fig.39

5. Turn the chuck clockwise (or counterclockwise) until the lock ring is completely removed.



No one should stand in front of the wheel when removing the lock ring.

Continue to demount all components of the rim manually or with the disc tool.

6. When loosening the inner bead be sure not to damage the valve stem (fig.40).

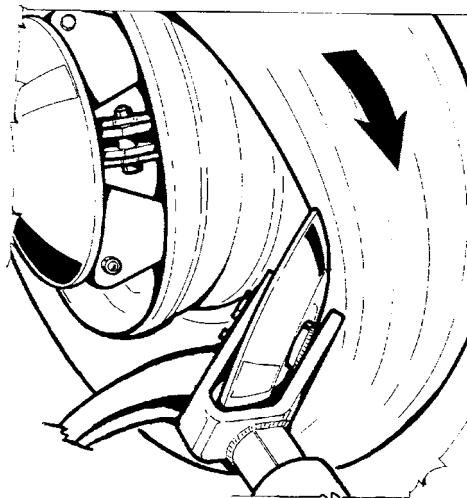

Fig.40

5.7 Mounting Tires Onto Multi-piece Rim/Wheel Assemblies

1. Roll the tire on the foot board (the tube and flap must be in place).

Note: O.T.R. tires and rims are very heavy and an outside lifting tool may be required.

For tube type only, the valve should be placed at 12 o'clock, for easier mounting.

2. Slide the tire onto the rim with the foot board or with the bead loosener disc, if necessary.

3. Mount all the assembly components.

4. Engage one edge of the lock ring in its seat and complete the mounting process with the bead loosener disc.

In the initial mounting phase hold the rim edge in its seat with a bar (fig.41).

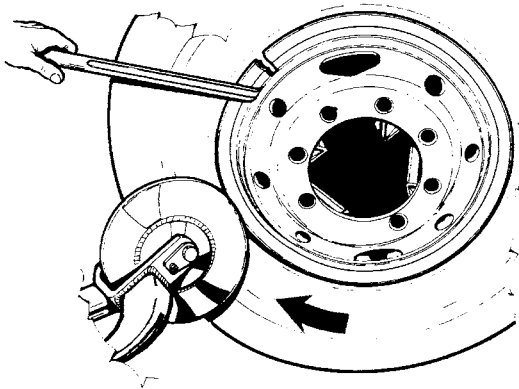

Fig.41



Do not inflate the tire on the machine. This machine is not an inflation device.

For inflation place the wheel in an approved inflation restraint device. Refer to OSHA standard number 1910.177.

5.8 Demounting Tractor and O.T.R. Wheels With One-Piece Rims

These wheels may be tube-type or tubeless. The rim has a slightly conical surface and a very high rim flange (fig.42) which does not allow you to demount the tire by simple pressure from the roller as described in @5.2.

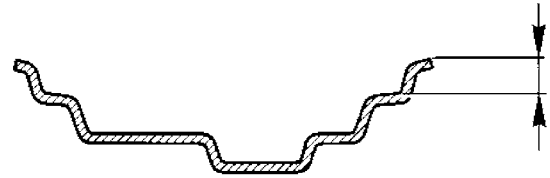

Fig.42

1. Remove all wheel-weights from the rim. Remove the valve stem or core and deflate the tire completely.

2. Place the disc tool next to the rim edge and loosen tire inner bead.

3. Loosen the outer bead in the same way, taking care not to damage the valve stem (fig.43).

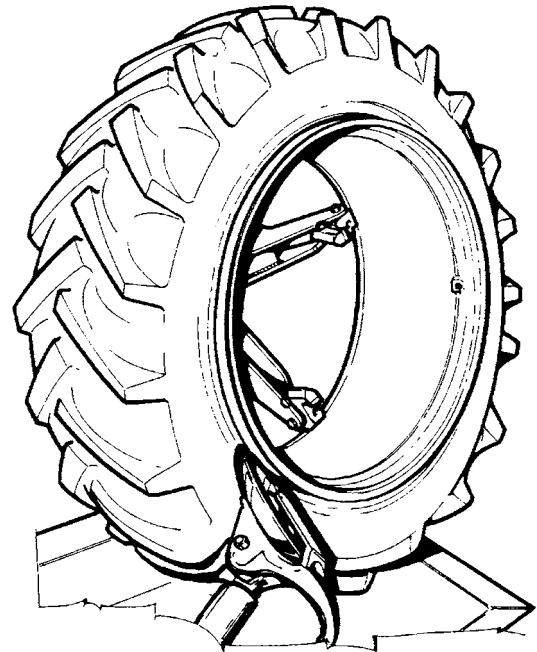

Fig.43

4. Lubricate both beads and the rim surface (fig.44).

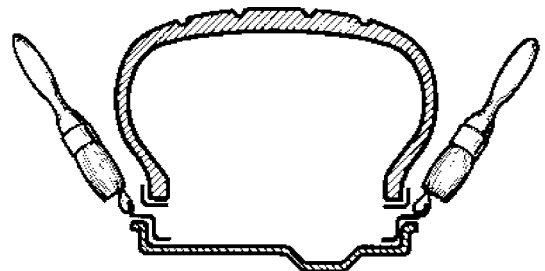

Fig.44

5. Place the hook tool between bead and rim (fig.45).



Fig.45

6. Lift the chuck arm to move the hook tool away from the rim edge (1" or 2-3 cm).

Move the tool towards the outside to apply the long tire bar (fig.46).

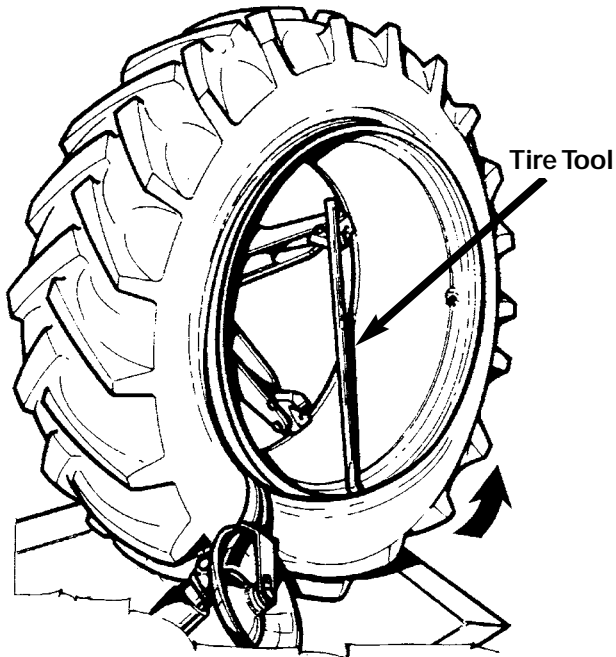

Fig.46

7. Turn the chuck counterclockwise until the outer bead is completely demounted (fig.47).

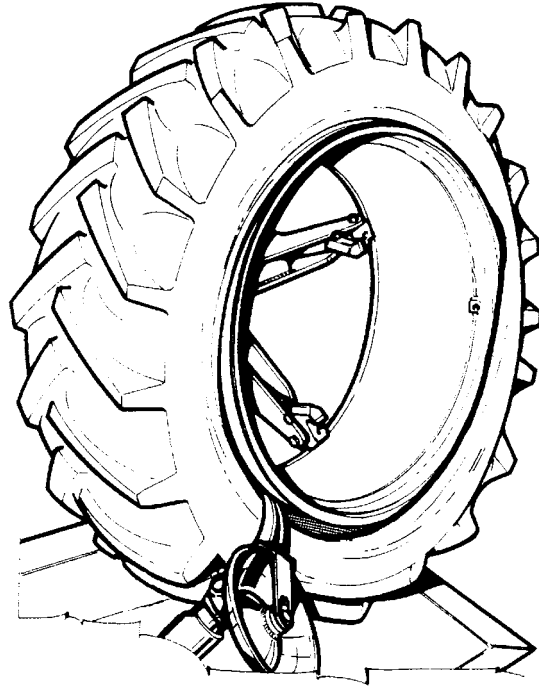

Fig.47

8. If the tire is tube-type, push the valve stem towards the inside of the rim.

9. Lift the tool holder arm to the rest position.

Shift the tire from the rim, moving the tool holder carriage towards the outside: This will make it much easier to remove the tube (fig.48).

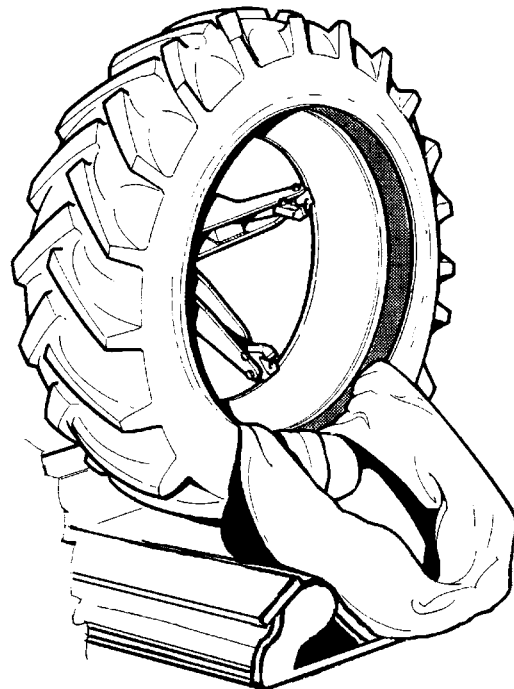

Fig.48

10. Place the hook tool as in fig.49. The edge of the hook should be about 1" (2-3 cm) away radially from the rim edge and about 1" (2-3 cm) to the outside.

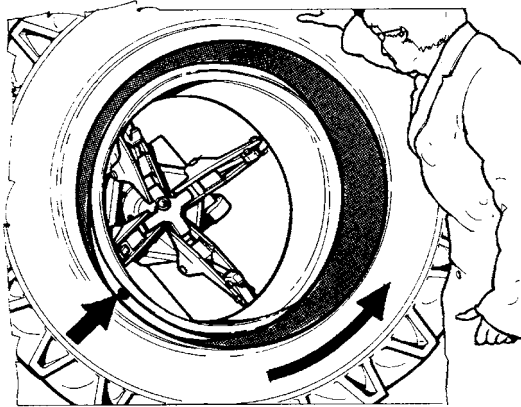

Fig.49

11. Put the long tire bar in between the bead and the rim.

12. Rotate the chuck counterclockwise until the tire is completely demounted.



During the final phase of the demounting operation remove the tire bar and hold the tire with both hands, in order to keep it in a vertical position.

5.9 Mounting Tractor And O.T.R. Wheels On One-piece Rims

1. Liberally lubricate both beads and the rim.

2. Firmly fit the mounting clamp to the outer rim flange at 9 o'clock.

Roll the tire onto the foot board and hang it on the mounting clamp attached to the rim edge.

3. Place the hook tool as shown in fig.50.

The edge of the hook should be about (1" or 2-3 cm) away radially from the rim edge and (1" or 2-3 cm) to the outside.

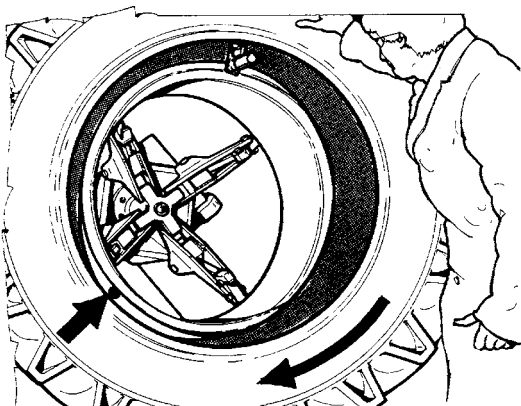

Fig.50

4. Turn the chuck clockwise until the first bead is mounted. Remove the clamp.

5. Place the tube (if any) in the tire and secure the valve stem to the rim.

6. Firmly fit the mounting clamp to the outer rim edge at 11 o'clock with valve stem at 10 o'clock in such a way as to hold the outer bead. If necessary make use of the tool to create the space to fit the clamp.

7. Place the hook tool as described in 5.5.2. Rotate the chuck clockwise till the tire bead is completely mounted. If necessary, use the bead bar to keep the bead in the drop center (fig.51).

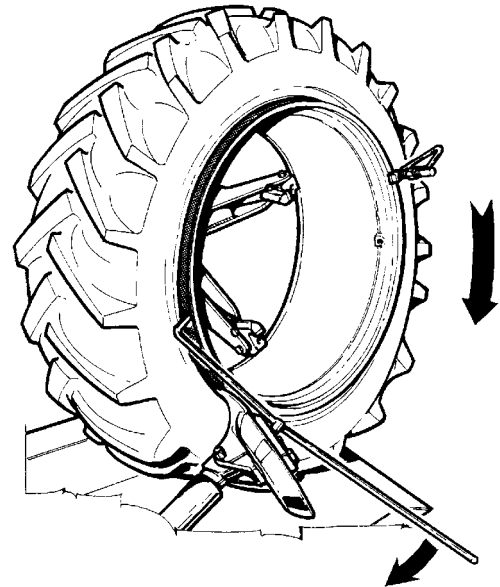

Fig.51



Do not inflate the tire on the machine. This machine is not an inflation device.

For inflation place the wheel in an approved inflation restraint device. Refer to OSHA standard number 1910.177.

6.0 Maintenance



Before starting any maintenance operation ensure that no wheel is mounted on the chuck and that the machine is disconnected from the electric supply.

1. Lubricate all points provided once a month (fig.52).

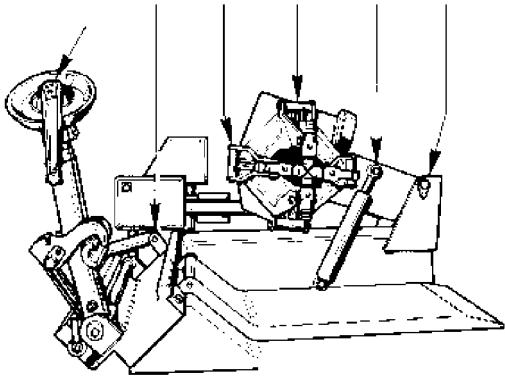

Fig.52

2. Once a month check the oil level of the speed reducer (fig.53). The chuck arm should be completely lowered when the check is performed.

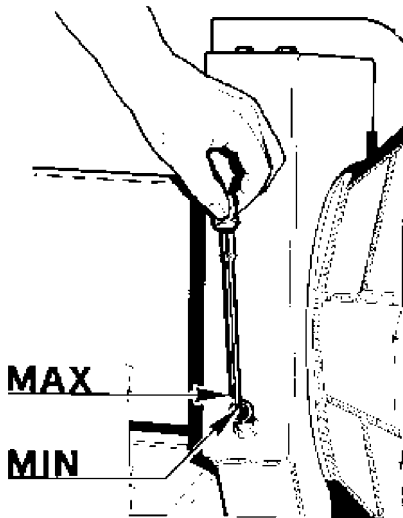

Fig.53

3. Check hydraulic oil level once a month (fig.54).

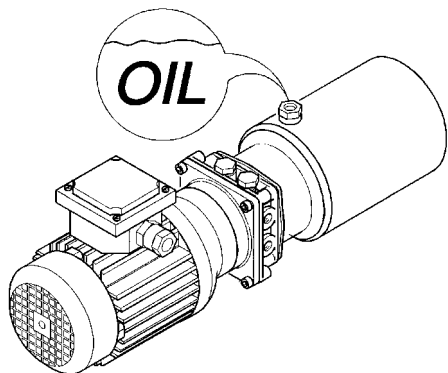

Fig.54

Note: Before checking, all cylinders must be completely retracted.

If necessary add:

Esso : nuto h 46

Shell : tellus oil 46

Total : azolla 46

Oil change is not required.

4. Clean & grease the sliding bar once a month (fig.55).

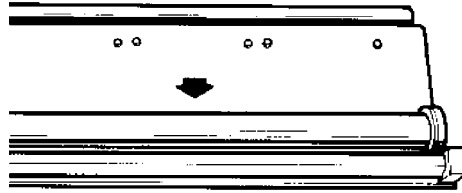

Fig.55

5. Clean the jaws of the chuck with a wire brush once a month.

7.0 Moving The Machine

In case the machine is to be moved from one working place to another, proceed as follows:

Disconnect the machine from the electric supply. Before lifting the machine, ensure that the chuck is completely closed, the chuck arm lowered, and that the arm beam support and carriage beam support are in the position indicated in fig. 56.

Use belts of a length of 10 feet and capacity of 2200 lbs.

Hold the machine as depicted in fig.56.

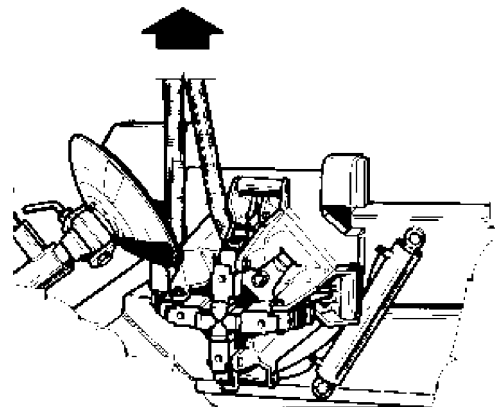

Fig.56

8.0 Storing The Machine

If the machine is to be idle for a long period of time (6 months or more) it is necessary to close the chuck arm, retract all hydraulic cylinders and disconnect all power sources. Protect all parts that may be damaged, protect the hydraulic hoses that may be damaged because of a drying process.

When putting the machine back in operation, first check the condition of all previously protected parts, and check for correct functioning of all devices before using the machine again.

10.0 Trouble Shooting

Trouble	Cause	Remedy
Pump motor turns but none of the hydraulic movement works.	<ul style="list-style-type: none"> • The automatic circuit breaker is off. • A fuse of the low-voltage section is blown. • Transformer is burned out. 	<ul style="list-style-type: none"> • Disconnect the machine from electric supply. Open the electric cabinet and check the automatic circuit breaker and low voltage fuses. Reset the circuit breaker or replace the fuses as needed. • This operation can be performed only by qualified personnel. • Call the authorized service center for assistance.
Pump motor does not turn but the chuck motor operates normally.	<ul style="list-style-type: none"> • The thermal safety switch protecting the hydraulic motor is/was activated. 	<ul style="list-style-type: none"> • Disconnect the machine from electric supply. Open the electric cabinet and reset the thermal safety switch. • This operation can be performed only by qualified personnel. • Call the authorized service center for assistance.
The thermal switch that protects the pump motor is very easily activated.	<ul style="list-style-type: none"> • The voltage of the electric line is too low. 	<ul style="list-style-type: none"> • Check voltage on electric supply. • This operation can be performed only by qualified personnel. • Call the authorized service center for assistance.
The circuit breaker is very easily activated.	<ul style="list-style-type: none"> • The machine is not stable on the floor. • The electric cabinet is not firmly attached. • The voltage of the electric line is too low. 	<ul style="list-style-type: none"> • Check that the machine is securely bolted to the floor. • Attach the electric cabinet firmly. • Check voltage on electric supply. • This operation can be performed only by qualified personnel.
The transformer protection fuses easily blow.	<ul style="list-style-type: none"> • Short circuit in the electric cord connecting the portable control unit to the electric cabinet. 	<ul style="list-style-type: none"> • Call the authorized service center for assistance.
The chuck does not hold the wheel firmly.	<ul style="list-style-type: none"> • The teeth of the chuck jaws are full of dirt or worn out. • The protectors for light-alloy wheels are damaged or worn out. • The check valve or manifold of the chuck cylinder leak oil. 	<ul style="list-style-type: none"> • Clean the teeth of the chuck jaws with a wire brush. • Replace the protectors for alloy wheels. • Call the authorized service center for assistance.

Truck Tire Changer Warranty Policy

The COATS® Company warrants the 9500 Truck Tire Changer to be free of defects in workmanship and material for a period of twelve (12) months from the date of installation. Labor will be covered by the COATS® Company for a period of 90 days from the date of installation.

Upon inspection by COATS® Company or its authorized representative, any defect in workmanship and/or material within the warranty period will be:

Replaced in the field by the user, parts supplied free of charge by the COATS® Company, LaVergne, Tennessee, for the first 12 months of operation. Labor is covered by the COATS® Company for the first 90 days of operation.

This warranty is in lieu of all other warranties, expressed or implied, and of all other obligations and/or liabilities, and no person is authorized to make any other representation or assume any other obligation on behalf of the manufacturer.

This warranty shall not apply if damage is due to accident, negligence, alteration, abuse or misuse, worn parts, installation by unlicensed electrician, or has not been operated in accordance with the manufacturer's instructions for operation. Parts replaced under warranty will assume the remainder of the unit's warranty period. Only parts and accessories manufactured by the COATS® Company will be warranted as stated above and this warranty shall not apply to the tire changer or any parts thereof if parts and accessories not manufactured by COATS® Company are used as replacements for or in substitution of COATS® Company manufactured parts and accessories.

To validate warranty:

1. A licensed electrician must install all electrical requirements and sign the attached warranty registration card.
2. The owner must fill out the post-paid warranty registration card and return it to COATS® Company within thirty (30) days of installation.

Failure to perform 1 above will void warranty coverage on electrical and hydraulic components. Failure to perform 2 may void entire warranty.

Service Policy

Upon recognition of a problem, review the **Maintenance Instructions** and **Service Manual**.

If further assistance is required, call:

(800) 688-6359
or
your nearest
Hennessy Regional
Office

The COATS® Company will supply a replacement part "no charge" when it is determined by the factory or an authorized representative that the part is defective in workmanship and/or material and is covered by the warranty policy. The owner has the option to send the defective part to the COATS® Company for inspection, repair or replacement. All returns to the factory must be authorized by the COATS® Company prior to return. Freight to the factory will be paid by the owner. If the machine is serviced by COATS® authorized personnel, labor charges will be covered for a period of 90 days after the date of installation.