

# Evolution

5-7.5 HP QUIET ENCLOSED RECIPROCATING AIR COMPRESSORS

▶ Auto body  
& tire shops



▶ Woodworking  
facilities



▶ Agriculture

▶ General Industrial

▶ Dry cleaning



**CHAMPION**<sup>®</sup>

# Which compressor is right for me?

When purchasing an air compressor, many people often ask:

**“Is a rotary screw or reciprocating compressor right for me?”**

Today, the choice of air compressors is abundant. A number of factors determine the answer to this question, including the operating requirements, application, and budget.

Ideal for constant-volume applications, rotary screw compressors are used extensively in applications above 30 hp and are often limited to a maximum air pressure of 150 psig. Rotary screw compressors typically have a higher initial cost than reciprocating compressors and require costly maintenance programs. Common advantages include a low noise level, low vibration, and 100% duty cycle.

Reciprocating (piston) air compressors are widely considered as ‘work-horse’ compressors. They may be seen in the corner of the garage, in auto body and tire shops, woodworking facilities, hospitals, construction sites, amusement parks, and industrial facilities. Industrial reciprocating compressors are able to operate in a *severe duty* environment, have *lower initial costs*, lower maintenance costs, and are ideal for *intermittent duty* operation. They *save energy* in no-load conditions and operate *efficiently* at partial loads, which results in a higher overall efficiency for many diverse applications. Piston compressors are *more forgiving* than rotaries and normally operate more dependably in less than ideal conditions.

Historically, it was not possible to provide the benefits of a reciprocating compressor in a low noise application. For this reason, rotary screw compressors have been misapplied in intermittent duty applications, resulting in frequent downtime, inefficient operation, problems with condensate, and higher maintenance costs.





## COMPRESSOR SELECTION GUIDE

Industrial Reciprocating*	Rotary Screw
Intermittent duty applications	Constant volume applications
Lower initial cost	Higher initial cost
Lower maintenance costs	Higher maintenance cost
Easy maintenance	Requires structured maintenance programs
Typical pressure range up to 175 psig	Typical pressure range 100 to 150 psig
Typically 30 hp & below	Typically above 30 hp
Can operate in harsh environment	Requires ideal operating conditions
Low sound <b>NOW</b> available	Low sound available

\* Single-acting lubricated

If you desire the advantages of a reciprocating compressor and the low noise of a rotary screw... it is time for you to meet *Evolution*.



# Evolution: The All-in-One Solution

The Champion Evolution provides the advantages of a reciprocating compressor coupled with the low noise of a rotary screw. Ideal for areas with a low noise

requirement, Evolution can be installed directly within the work environment close to the point-of-use. This eliminates the need for a dedicated room or an outside installation and can save hundreds of feet in piping resulting in reduced pressure drops, ultimately increasing your bottom line.

## ev•o•lu•tion

Function: *noun*

- any process of formation or growth; development
- a product of such development; something evolved

Source: [www.dictionary.com](http://www.dictionary.com)

The New Champion Evolution is a prime example of a product that has evolved through analysis of our customers' needs and expectations. Evolution establishes a precedence in innovation, quality, reliability, long life and high performance.

The majority of reciprocating compressors' discharge temperatures reach in excess of 400° F. In most competitive products, the compressor and the motor are enclosed together in the same cabinet. The heat from the compressor operation increases the electric motor operating temperature, thus reducing the motor's service life and long-term reliability. Unlike the competitors' products, Evolution offers *two separate cooling circuits* with each one pulling in cool ambient air. With the electric motor operating in its own isolated area of the package, Evolution ensures the temperatures outlined by the motor manufacturer are not exceeded. *Evolution is the reciprocating compressor you can depend on for reliability and quiet operation.*

A one-piece powder coated inner base supports both the compressor and the motor. Rubber vibration isolators separate the inner base from the enclosure for maximum noise and vibration control. The sound attenuating enclosure, made of 16 gauge steel with additional foam insulation, enables the compressor package to run quieter. Additional vibration pads between the enclosure and the tank are added for unmatched quiet operation.









*"I always had a rotary screw compressor because of its low noise level, however, I continuously had problems with it due to its frequent start/stop operation. With the Evolution, I now have the right compressor for my application and can keep the low noise of my rotary. Thank you, Champion!"*

– Rick Hinkel

Hinkel AutoBody, Houston, TX

### Evolution Air Flow Diagram

-  Motor hot air
-  Compressor hot air
-  Compressor cooling air
-  Motor cooling air

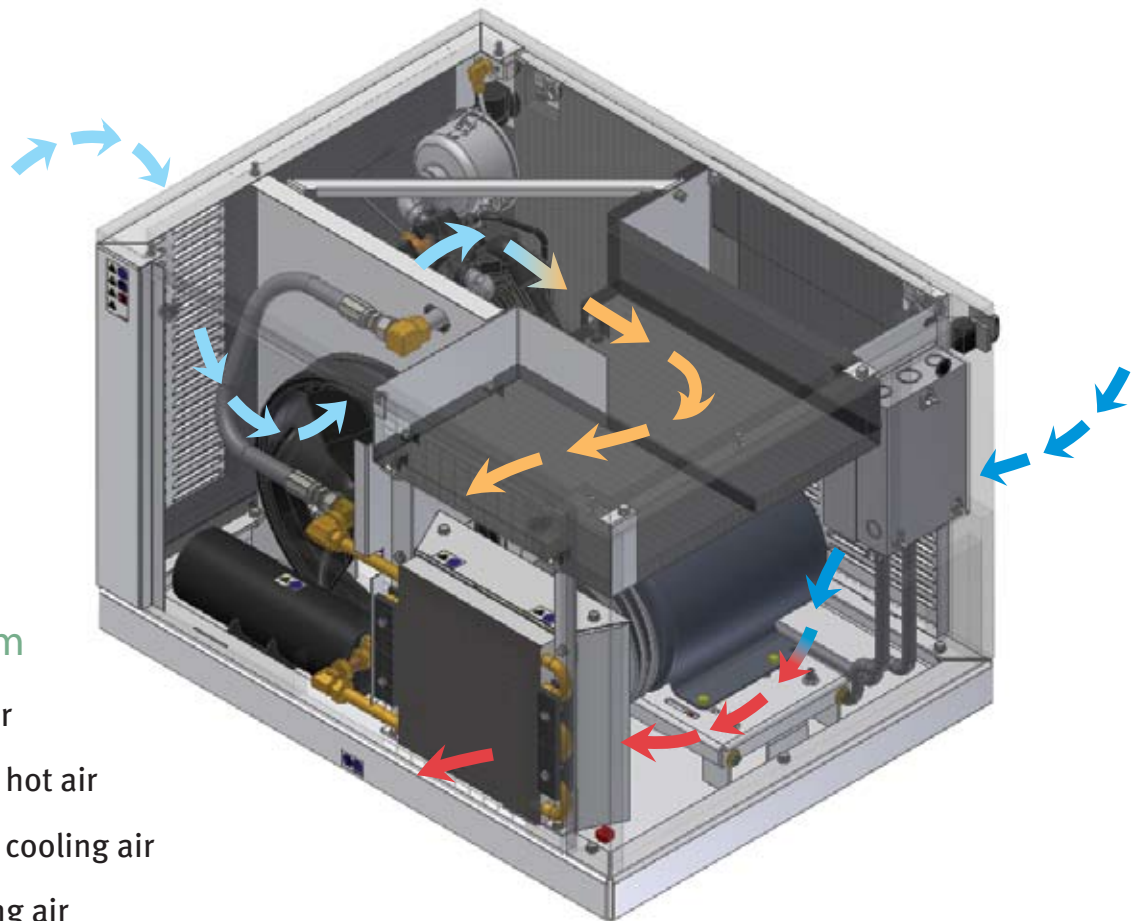

# Quality Accessories

## Competitive Advantages & Customer Benefits

1. Separate compressor and motor chambers with dedicated cooling circuits for *cooler operation and longer life*.
  2. Oil site gauge for *ease of monitoring and service*.
  3. Integrated heavy-duty air cooled aftercooler for *up to 65% moisture removal*.
  4. Filter maintenance indicator provides *user-friendly monitoring*. The graduated indicator monitors the compressor air filter. The position indicator progressively fills the window as air filter restriction increases and indicates the need for a filter change.
  5. Industrial grade compressor incorporates unique features including gasketless cylinder/head design, stainless steel valve disks and tapered roller main bearings for *superior dependability*.
  6. Innovative belt tensioning system for *easy service*.
  7. Axial flow fan for *superior cooling* of electric motor.
- Superior 24-hour *service support* and *genuine replacement parts*.
  - Incredible *Five-Year warranty*.

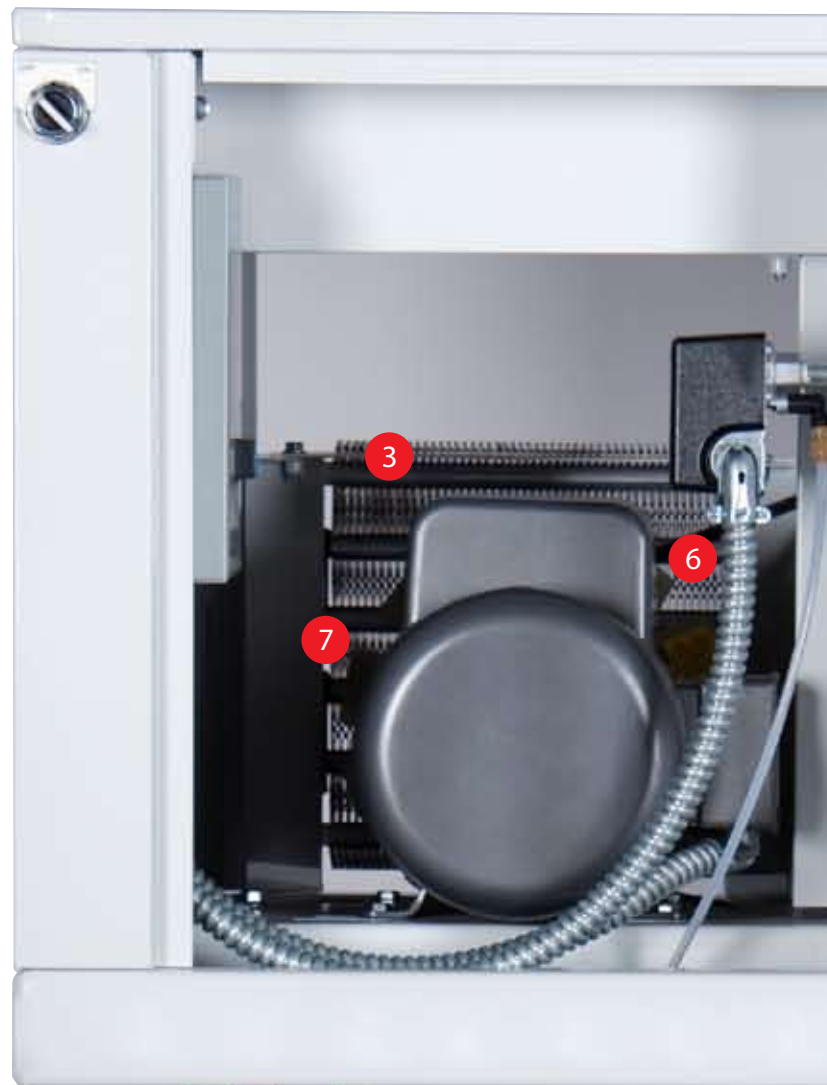

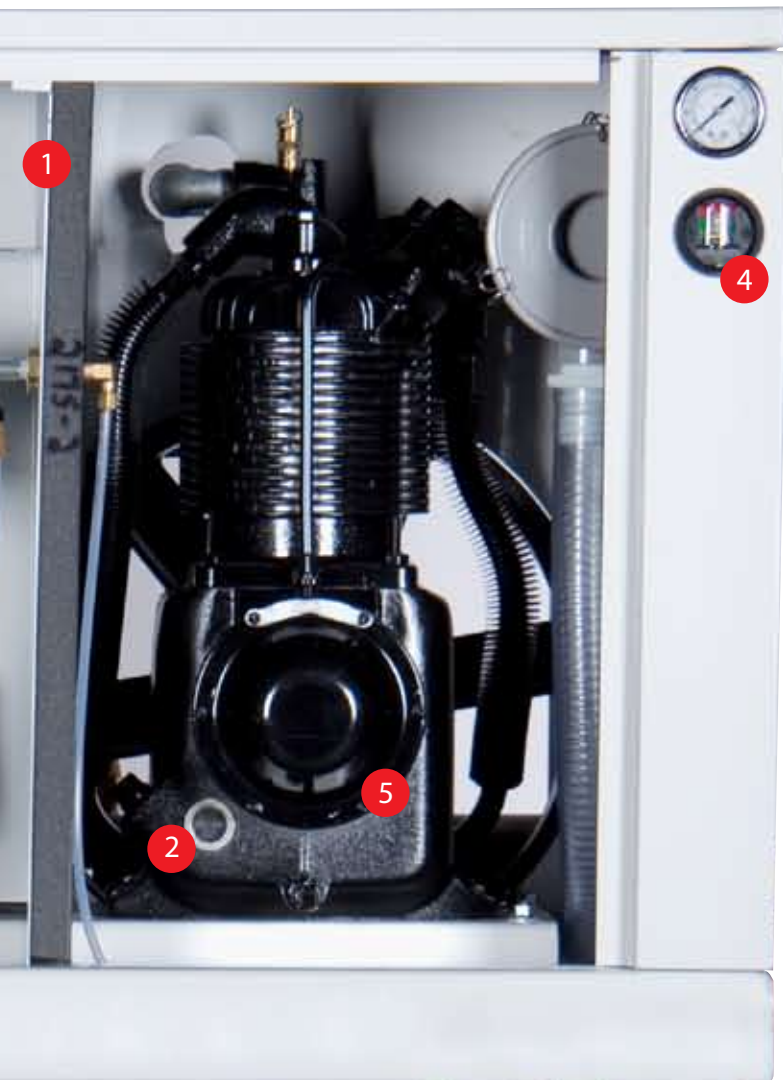

### Standard Features

- Magnetic starter for thermal overload protection
- Manual tank drain
- Standard start/stop control
- Sound attenuating enclosure for low noise operation
- Front and back panels can be easily removed for fast and easy service access
- Ball valve on crankcase drain for easy maintenance of lubricant
- Package easily fits through a standard 36" door
- 80/20 duty cycle

### Optional Accessories

- NEMA 4 Starter/Pressure switch
- Moisture Separator
- Dual Control
- Low Oil Level Shutdown
- High Temperature Shut Down
- Electric Tank Drain
- TEFC Motors
- Premium Efficiency Motors
- Vibration Isolators

# Design Advantages

## Competitive Advantages & Customer Benefits

1. Integral cylinder and head eliminating the possibility of blown head gaskets for *leak-free, trouble-free operation*.
2. Balanced aluminum alloy first stage piston(s) are weight matched to the cast iron second-stage piston(s) for *proper balance and minimized vibration*. Unique domed piston design for *maximum air delivery and efficiency*.
3. Lightweight, high-density, die-cast aluminum alloy connecting rods for *minimal reciprocating weight*. Precision-bored crankpin bearing and piston pin needle bearing are used to properly distribute bearing loads for *longer bearing life* than bushings.
4. Industrial grade, reliable, high-flow, low lift disc-type valves are made of corrosion resistant Swedish steel to ensure years of *trouble free* operation.
5. Tapered roller-type main bearings, providing full contact and support of the crankshaft, ensuring compressor *durability and long-life*.

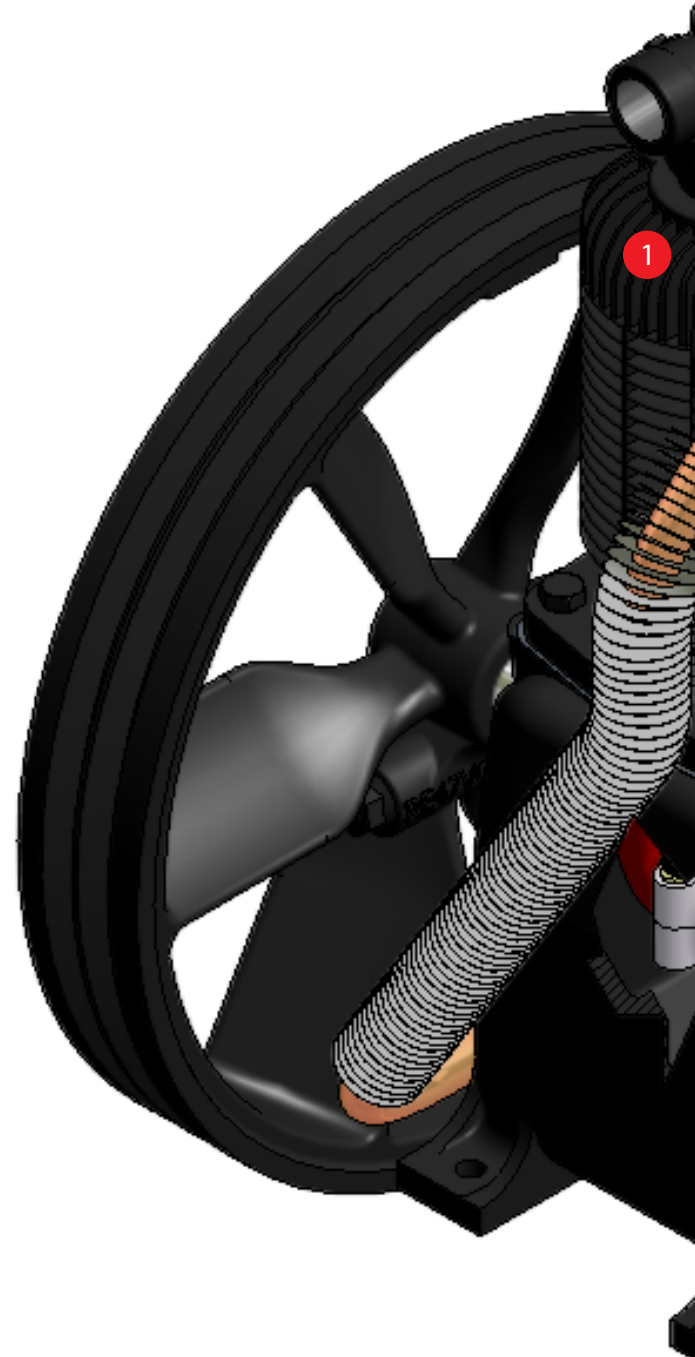

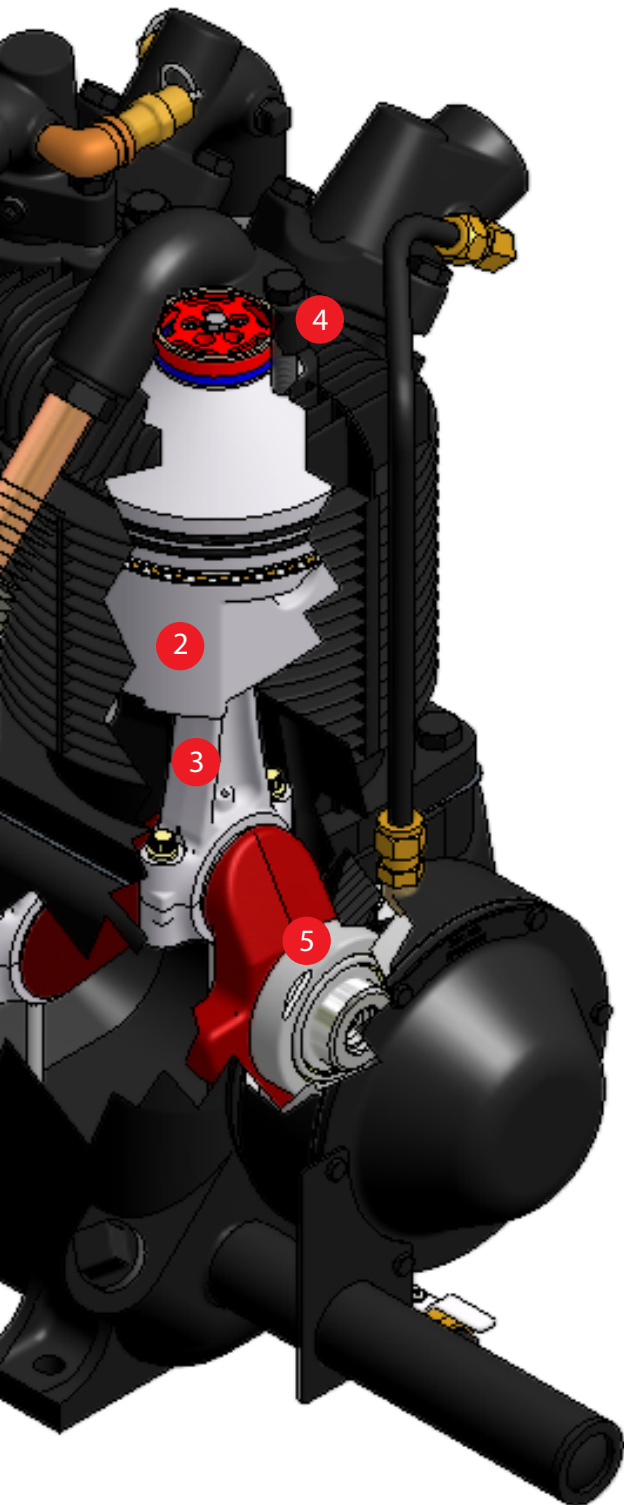

## Standard Features

- Multi-finned cylinders for cooler operating temperatures resulting in long life and consistent performance.
- Three compression rings and one oil control ring to ensure low oil carry-over and provide efficient air delivery.
- Large-diameter finned tubing with the greatest cooling effect between stages for maximum compressor efficiency.
- Pressure relief valves located in inter-stage intercooler and discharge line for safe compressor operation.
- Precision balanced flywheel with cast fan blades for optimum compressor cooling and longer life.
- Removable manifolds for easy serviceability.
- Balanced rugged ductile iron crankshaft with large diameter throws for minimum bearing loads and counterweights to minimize vibration.
- Rugged cast iron oil reservoir with convenient sight gauge glass, corner oil fill boss and large oil drain for user-friendly serviceability.
- Positive acting, governor-type centrifugal unloader allows the compressor to start unloaded every time. This ensures the lowest amount of starting torque is required by the electric motor.

# Time-proven Engineering Excellence

Today's Champion compressors are the product of decades of rigorous design and development. With over 90 years experience in designing and manufacturing air compressor systems, Champion compressors have been continuously improved in design and performance through innovation in engineering, material, production techniques, and quality control.

During the development of the Evolution, the voice of our customers was a top priority. After a thorough analysis of our customers' needs and expectations, we developed a unique compressor with unmatched performance and reliability.

Featuring time-proven design and dependability, high performance and long life, Champion is a true leader in reciprocating compressors.

*Throw away your loud compressor and buy a Evolution!*

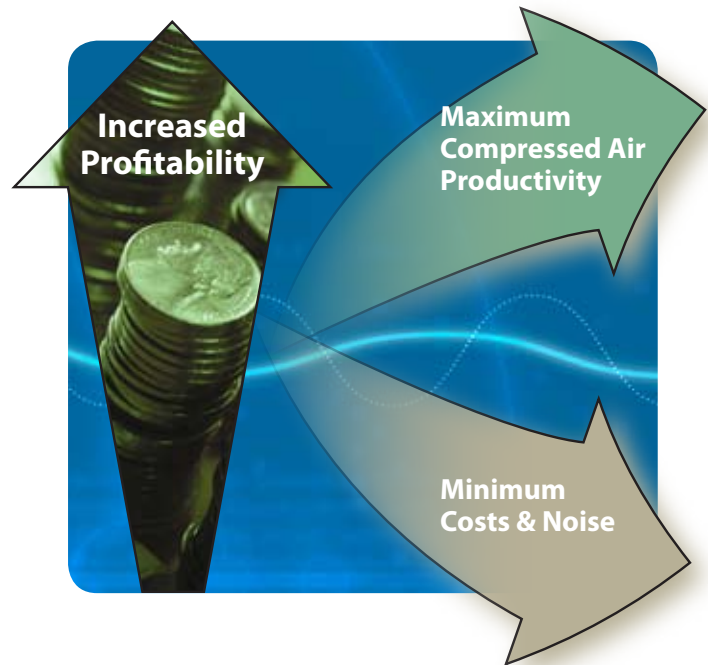

## Finite Element Analysis (FEA)

*Structural analysis*

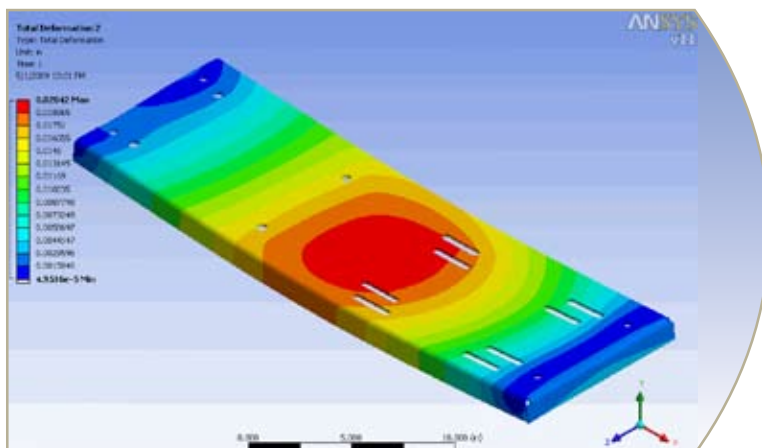

Champion evaluated several designs using FEA structural analysis. With FEA, Champion engineers created a more rigid base to counter resonance, fatigue and vibration.



## Sound Testing



Evolution tested to CAGI adopted  
ISO 2151 certified standards

With a commitment to research and development, Champion provides our customers with products which uphold our tradition of quality and proven results. As part of the new product development process, the Evolution has passed extensive design reviews as well as performance, endurance and sound testing requirements.

### BASE MOUNTED UNITS

Motor HP	Stockable Variant CABQEA	Pump Comp Model	L x W x H Dimensions inches	Aprox. Ship Wt.lbs.	Sound Level (dBA)	175 PSI Rating*		
						RPM	CFM Displ.	CFM Del'y
5	BER-5	R-15B	40½ x 31½ x 31	505	67	734	21.3	16.8
7½	BER-7F	R-15B	40½ x 31½ x 31	534	68	990	28.7	22.4

### HORIZONTAL TANK MOUNTED UNITS

Motor HP	Tank Cap Gal.	Stockable Variant CASQEA	Pump Comp Model	L x W x H Dimensions inches	Aprox. Ship Wt.lbs.	Sound Level (dBA)	175 PSI Rating*		
							RPM	CFM Displ.	CFM Del'y
5	80	HER5-8	R-15B	67 x 31½ x 53½	733	67	734	21.3	16.8
7½	80	HER7F-8	R-15B	67 x 31½ x 53½	762	68	990	28.7	22.4

\*Units tested in accordance with CAGI/PNEUROP Acceptance Test Code PN2CPTC2.

# Other Innovative Products



**CFF Series**  
High Efficiency Filters

A full range of filters 20–21,250 cfm; coalescing, particulate, and activated carbon for the removal of water, oil, and particulates from compressed air.



**CDT Series**  
Desiccant Dryers

A complete line of desiccant dryers for the removal of water vapor in compressed air to dew points as low as -100° F.



**CRN Series**  
Refrigerated Dryers

A full line of high quality refrigerated dryers with features and benefits unmatched by the competition. Designed to produce dew points as low as 38° F in compressed air.



1301 North Euclid Avenue  
Princeton, Illinois 61356 USA  
Phone 888/436-5499  
Fax 815/872-0421  
E-mail: [Champion@championpneumatic.com](mailto:Champion@championpneumatic.com)  
[www.ChampionPneumatic.com](http://www.ChampionPneumatic.com)



Please recycle after use.



Member

